

# PP-100N Security

## *Administrator's Guide*

M00012700

**Disc** producer™

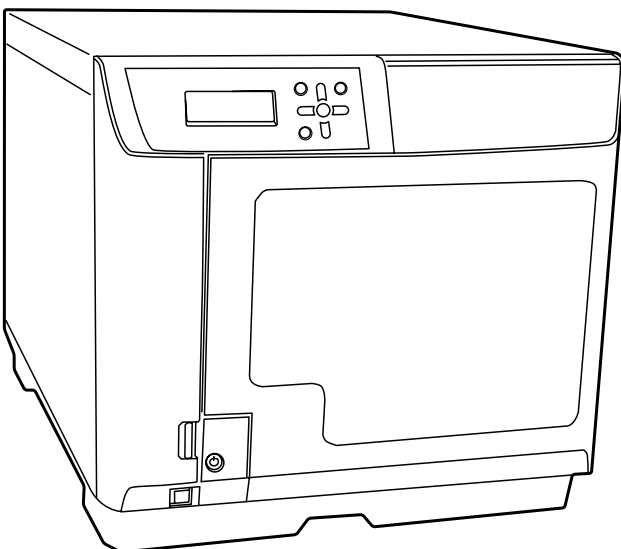

All rights reserved. No part of this publication may be reproduced, stored in a retrieval system, or transmitted in any form or by any means, electronic, mechanical, photocopying, recording, or otherwise, without the prior written permission of Seiko Epson Corporation. No patent liability is assumed with respect to the use of the information contained herein. While every precaution has been taken in the preparation of this manual, Seiko Epson Corporation assumes no responsibility for errors or omissions. Neither is any liability assumed for damages resulting from the use of the information contained herein.

Neither Seiko Epson Corporation nor its affiliates shall be liable to the purchaser of this product or third parties for damages, losses, costs, or expenses incurred by purchaser or third parties as a result of: accident, misuse, or abuse of this product or unauthorized modifications, repairs, or alterations to this product, or (excluding the U. S.) failure to strictly comply with Seiko Epson Corporation's operating and maintenance instructions.

Seiko Epson Corporation shall not be liable against any damages or problems arising from the use of any options or any consumable products other than those designated as Original EPSON Products or EPSON Approved Products by Seiko Epson Corporation.

**NOTICE:** The contents of this manual are subject to change without notice.

Copyright © 2009 Seiko Epson Corporation. All rights reserved.

## Trademarks

- Microsoft, Windows, Windows Vista and Internet Explorer are registered trademarks of Microsoft Corporation in the United States and other countries.
- EPSON is a registered trademark of Seiko Epson Corporation.

Other product names are trademarks or registered trademarks of their respective owners.

## Marks used in this guide

The following marks are used in this guide to indicate important information.



Indicates information with which you must comply when using this product. Ignoring this information and mishandling the product may cause it to fail or malfunction.

### Notes

Indicates an additional explanation or information we want you to know.

## Screens appearing in this guide

Unless otherwise indicated, the Windows screens appearing in this guide are Vista screens.

## Organization of this manual

The following instruction guides are included with this product.

PP-100N Setup Guide	Briefly describes how to set up this product using Standard Mode, External Output Mode and Batch Mode in 25 languages with illustrations. See the <b>PP-100N Administrator's Guide</b> for more information.
PP-100N User's Guide (PDF)	Presents detailed information users need to know when using this product in Standard Mode, External Output Mode, and Batch Mode, such as how to install the software, the product functions and operations, as well as maintenance information. It is included on the PP-100/PP-100N Utility & Documents disc.
PP-100N Administrator's Guide (PDF)	Presents detailed information necessary for setting up, operating, and managing this product when using it in Standard Mode, External Output Mode, and Batch Mode. It also describes how to troubleshoot various problems. It is included on the PP-100/PP-100N Utility & Documents disc.
PP-100N Security Setup Guide	Briefly describes how to set up this product using PIN Controlled Mode and Security Mode in 25 languages with illustrations. See the <b>PP-100N Security Administrator's Guide</b> for more information.
PP-100N Security User's Guide (PDF)	Presents detailed information users need to know when using this product in PIN Controlled Mode and Security Mode, such as how to install the software, the product functions and operations, as well as maintenance information. It is included on the PP-100N Security-Documents disc.
PP-100N Security Administrator's Guide (PDF)	Presents detailed information that administrators need to know about setting up, operating and managing this product when using it in PIN Controlled Mode and Security Mode. It also describes how to troubleshoot various problems.

# Table of Contents

Trademarks.....	2
Marks used in this guide.....	2
Screens appearing in this guide.....	2
Organization of this manual.....	3
■ Table of Contents.....	4

---

## **Before Using This Product..... 6**

■ For safe use.....	6
Cautions for the power source.....	8
Cautions for using.....	9
WARNING.....	11
FCC compliance statement for American users.....	11
For Canadian users.....	11
For California customers only.....	11
■ Cautions for CD/DVD discs.....	12
■ Uses of this product.....	12
■ Incidental loss arising from the use of this product.....	12
■ Restriction of Use.....	12
■ About open source software licenses.....	12

---

## **PIN Controlled Mode and Security Mode..... 13**

Publish Mode.....	13
Security control mechanisms.....	15
System configuration.....	15
■ Secure disc creation.....	16
Roles of the person in charge and the users (administrators, approvers, publishers).....	16
What is a secure disc creation environment?.....	17

---

## **Preparation..... 18**

■ Installation.....	18
Installation location requirements.....	19
Installation space.....	19

■ Setup procedure.....	20
■ Connecting the authentication keypad.....	21
■ Connecting the Ethernet cable.....	25
■ Connecting the power cord.....	25
■ Installing the ink cartridges.....	26
■ Setting the security lock switch.....	30
■ Setting the Publish Mode.....	31
Types of Publish Modes.....	31
Installing the stackers.....	32
Setting procedure.....	34
■ Network settings.....	36
■ Registering an administrator.....	42
■ System settings.....	47
Output device settings.....	47
Notification email transmission settings.....	50
Setting the date and time.....	54
■ Installing digital certificates.....	56
Creating a CA certificate and server certificate.....	57
Downloading the CA certificate.....	59
Downloading the server certificate.....	60
Uploading the server certificate.....	61
■ Setting the language.....	62

---

## **Administration and Management..... 63**

■ Closing and opening the disc cover.....	63
Unlocking the disc cover.....	63
Opening the disc cover.....	65
Closing the disc cover.....	66
■ Loading discs.....	67
■ Managing jobs.....	68
Checking job information.....	68
Canceling job applications (Security Mode only).....	70
Checking the job processing status.....	72
Pausing jobs.....	73
Resuming jobs.....	74
Canceling jobs.....	75
Deleting jobs.....	76
■ Managing users.....	78
Checking user information.....	78
Registering users.....	79
Batch registering users.....	82

Changing user information.....	85
Deleting user information.....	87
Changing password and PIN.....	89
Unlocking the user account .....	92
■ Managing inspection logs.....	94
Checking inspection logs .....	94
Downloading inspection logs.....	96
■ Changing the Publish Mode.....	97
Mode change II.....	98
Mode change III.....	100
Mode change IV.....	102

---

## **Maintaining Your Product..... 104**

■ Backing up and restoring data .....	104
Backing up data.....	104
Restoring data.....	106
■ Restoring to initial state .....	107
■ Checking maintenance information.....	111
Checking device information .....	111
Downloading operation log.....	113
■ Checking the TOE version (Security Mode only) .....	114
■ Starting Service Mode .....	115
■ Precautions for transporting your product .....	117

---

## **Troubleshooting..... 119**

■ Error messages and remedies.....	119
■ Problems and their remedies.....	126
Power/Control Panel problems.....	126
Disc writing problems .....	127
Label printing problems.....	128
Password/PIN problems .....	130
Other problems.....	131
■ Checking with EPSON Total Disc Monitor .....	133
■ When discs cannot be published .....	135
■ Disc does not come out .....	138
Drive tray does not come out .....	138
Printer tray does not come out.....	139

■ Disc recording surface is stained with ink.....	143
---	-----

---

## **Appendix..... 147**



■ Where to get help .....	147
Before contacting Epson .....	147
Help for users in the United States and Canada .....	147
Help for users in Europe (EMEA).....	147
■ Product specifications .....	148
Basic specifications.....	148
■ Ink and Disc.....	153
Ink cartridges .....	153
Discs .....	153





# Before Using This Product

## For safe use

- To use this product safely, be sure to read this guide as well as the other instruction guides included with this product before using it.
- Keep this guide at hand so that you can resolve any questions you have about this product.

To prevent harm to customers and other people or damage to property, this guide contains the following symbols and warning displays for operations and use that may be dangerous. Please read the guide after thoroughly understanding this information.

 <b>WARNING</b>	If this display is ignored and the product is mishandled, it may result in death or serious injury.
 <b>CAUTION</b>	If this display is ignored and the product is mishandled, it may result in bodily harm or physical damage.





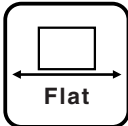
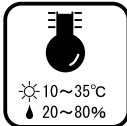

	Indicates action that should not be performed (prohibited).		Indicates that the product must not come in contact with water.
	Indicates that disassembly is prohibited.		Indicates that the plug should be disconnected from the outlet.
	Indicates that contacting the product with wet hands is prohibited.		

Install this product in the following type of place.











Place that is flat and stable	Place with the following temperature and humidity range
	

- When using this product in a place where static electricity is easily generated, use an antistatic mat or other product to prevent static electricity.
- Do not install on a surface that is smaller than the base of the product.  
 If the rubber bases on the bottom of the product extend beyond this surface, it places stress on the internal mechanisms, which negatively affects disc writing, printing and transporting. Be sure to install on a flat surface that is wider than the product so that all of the feet on the base of the product rest firmly on it.





















 <b>WARNING</b>	<ul style="list-style-type: none"> <li>• <b>Do not use flammable gas sprays inside or around this product. There is a risk that gas will build up and a spark may cause a fire.</b></li> <li>• <b>Do not install in a place where volatile substances, such as alcohol or paint thinner, are present or in a place where there is fire.</b> This may result in electric shock or fire.</li> </ul>	
 <b>CAUTION</b>	<p><b>Place the product on a flat, stable surface that extends beyond the base of the product in all directions. If you place the product by the wall, leave more than 10 cm between the back of the product and the wall. The product will not operate properly if it is tilted at an angle.</b></p>	
	<p><b>Do not install or store in an unstable place (such as on a wobbly or tilted surface), in reach of children, or in a place subject to vibration from other machines.</b> There is a risk that it could drop or fall over, resulting in injury.</p>	
	<p><b>Do not install in places where there is excessive moisture or dust, risk of getting wet, direct sunlight, severe changes in temperature and humidity, or close to heating and cooling devices.</b> There is a risk of electric shock, fire, and malfunction or failure of this product.</p>	
	<p><b>Do not block the air vents on this product.</b> Blocking the air vents may result in internal heat build-up and fire. Do not install in the following types of places.</p> <ul style="list-style-type: none"> <li>• Tight spaces where ventilation is poor, such as in a closet or on a bookshelf</li> <li>• On a rug or bed</li> </ul> <p>If you place the product by the wall, leave more than 10 cm between the back of the product and the wall. It is also necessary to leave enough space in front of the product to open and close the disc cover.</p>	

## Cautions for the power source

 <b>WARNING</b>	<p><b>Do not connect or disconnect the power plug with wet hands.</b> This may result in electric shock.</p>	
	<p><b>Use only the type of power source indicated on the product's label. Also, do not plug the power cord into an outlet with many other cords connected to it.</b> Using an out-of-spec power source may result in electric shock or fire.</p>	
	<p><b>Do not use a damaged power cord.</b> This may result in electric shock or fire. If the power cord is damaged, consult your dealer for repairs. Observe the following when handling the power cord.</p> <ul style="list-style-type: none"> <li>• Do not modify the power cord</li> <li>• Do not place heavy objects on the power cord</li> <li>• Do not bend, twist or pull the power cord by force</li> <li>• Do not wire heating appliances nearby</li> </ul>	
	<p><b>Be careful when handling the power plug.</b> Mishandling may result in fire.</p> <ul style="list-style-type: none"> <li>• Do not leave plugged into a power source having foreign matter such as dust</li> <li>• Firmly insert the prongs of the power plug all the way</li> </ul>	
	<p><b>When you disconnect the power plug from the outlet, be sure to turn off the power and hold the plug as you pull.</b> If you stretch the power cord, it may become damaged, which could result in electric shock or fire.</p>	
	<p><b>Be sure your AC power cord meets the relevant local safety standard. Also, do not use the power cord included with this product with any other devices.</b> This may result in electric shock or fire.</p>	
	<p><b>For safety reasons, be sure to ground the power cord.</b> The power cord included with the product is a 3-pin cable with a power system grounding (PE) terminal, so connect it to an outlet with a grounding electrode and ground it securely.</p>	
 <b>CAUTION</b>	<p><b>Regularly disconnect the power plug from the outlet and clean the base of the prongs and between the prongs.</b> If you leave the power plug connected to an outlet for a long time, the base of the power plug prongs may become dusty, which may result in short circuit and fire.</p>	
	<p><b>For safety, be sure to disconnect the power plug from the outlet when you will not be using the product for a long time.</b></p>	

## Cautions for using

 <b>WARNING</b>	<p><b>Do not continue to use under abnormal conditions such as smoke, unusual odors or sounds.</b></p> <p>This may result in electric shock or fire. Immediately turn off the power, disconnect the power plug from the outlet, and contact your dealer or the Epson Repair Center about repairs. Servicing the product yourself is dangerous, so never attempt it.</p>	
	<p><b>Do not insert or drop metal or flammable objects into the air vents or other openings.</b></p> <p>This may result in electric shock or fire.</p>	
	<p><b>If a foreign object, water or other liquid enters the product, do not continue to use it.</b></p> <p>This may result in electric shock or fire. Immediately turn off the power, disconnect the power plug from the outlet, and contact your dealer or the Epson Repair Center about repairs.</p>	
	<p><b>Do not attempt to service the product yourself.</b></p> <p>This may result in injury, electric shock, fire or malfunction.</p>	
	<p><b>Do not leave containers of water or other liquid on this product.</b></p> <p>If water spills on or into the product, this may result in electric shock, fire, or malfunction.</p>	
 <b>CAUTION</b>	<p><b>Do not step on or place heavy objects on top of the product.</b></p> <p>Be especially careful in households with small children. There is a risk that it could fall over or break, resulting in injury.</p>	
	<p><b>Do not use the various cables (cords) to connect the product in a way other than that specified in the instruction guide.</b></p> <p>Faulty wiring may result in fire.</p>	
	<p><b>Do not connect a telephone line to the Ethernet interface connector.</b></p> <p>This may result in damage to the telephone line or this product.</p>	
	<p><b>When connecting this product to a computer (or other device) using a cable, be careful to orient the connector the right way.</b></p> <p>The connectors on the cables have a specific orientation. If you connect incorrectly oriented connectors to both this product and the computer (or other devices), this may result in the malfunction of both connected devices.</p>	

 <b>CAUTION</b>	<p><b>When storing or transporting this product, do not tilt it, stand it on end, or turn it upside down.</b>  When transporting the product, be sure to package it in the original box to protect it from any impact.</p>	
	<p><b>For safety reasons, if you move this product, first check that the power is off, the power plug is disconnected from of the outlet, and all of the wires are disconnected.</b></p>	
	<p><b>When replacing the ink cartridges, be careful that the ink does not contact your eyes or skin.</b>  Be especially careful because once an ink cartridge is used, there may be some ink around the ink supply port. If ink gets into your eyes, immediately flush them with water, and if it gets onto your skin, immediately wash the area with soap and water. Leaving the ink as is may result in bloodshot eyes or mild inflammation. In the rare event that there is a problem, immediately consult with a physician.</p>	
	<p><b>Do not disassemble the ink cartridges to replenish or refill the ink.</b></p>	
	<p><b>Do not shake the ink cartridges too hard.</b>  The ink cartridges may leak if you shake them around too much.</p>	
	<p><b>Store ink cartridges out of the reach of children. Also, do not ingest the ink.</b></p>	

**WARNING**

The connection of a non-shielded interface cable to this product will invalidate the EMC standards of this device. You are cautioned that changes or modifications not expressly approved by Seiko Epson Corporation could void your authority to operate the equipment.

This is a Class A product. In a domestic environment this product may cause radio interference in which case the user may be required to take adequate measures.

***FCC compliance statement for American users***

This equipment has been tested and found to comply with the limits for a Class A digital device, pursuant to Part 15 of the FCC Rules. These limits are designed to provide reasonable protection against harmful interference when the equipment is operated in a commercial environment.

This equipment generates, uses, and can radiate radio frequency energy and, if not installed and used in accordance with the instruction manual, may cause harmful interference to radio communications.

Operation of this equipment in a residential area is likely to cause harmful interference, in which case the user will be required to correct the interference at his own expense.

***For Canadian users***

This Class B digital apparatus complies with Canadian ICES-003.

***For California customers only***

The lithium batteries in this product contain Perchlorate Material - special handling may apply. See [www.dtsc.ca.gov/hazardouswaste/perchlorate](http://www.dtsc.ca.gov/hazardouswaste/perchlorate).

## ***Cautions for CD/DVD discs***

Before using this product, run an operation check to make sure it is functioning normally. Also, back up the data on CD/DVD discs onto separate media as necessary. Data may be damaged or lost at the following times:

- When there is static electricity or electrical noise
- During improper use
- During a malfunction or repair
- When there is damage due to a natural disaster

Even if the product is still under warranty, Epson accepts no responsibility for data that is lost or damaged due to causes not limited to those listed above.

## ***Uses of this product***

This product is for business use and not for household use.

## ***Incidental loss arising from the use of this product***

Should you not obtain the results you expect from this product, including the bundled software, we cannot provide compensation for incidental loss arising from that fact, such as expenses required for the use of this product and lost earnings that would have been gained through the use of this product.

## ***Restriction of Use***

When this product is used for applications requiring high reliability/safety such as transportation devices related to aviation, rail, marine, automotive etc.; disaster prevention devices; various safety devices etc.; or functional/precision devices etc., you should use this product only after giving consideration to including fail-safes and redundancies into your design to maintain safety and total system reliability. Because this product was not intended for use in applications requiring extremely high reliability/safety such as aerospace equipment, main communication equipment, nuclear power control equipment, or medical equipment related to direct medical care etc., please make your own judgment on this product's suitability after a full evaluation.

## ***About open source software licenses***

This product uses open source software in addition to Epson proprietary software. For a list of the open source software used in this product as well as license terms for this software, see Open Source Software License Agreement on the PP-100/PP-100N Utility & Documents Disc included with the product.

# PIN Controlled Mode and Security Mode

In addition to the regular modes (Standard Mode/External Output Mode/Batch Mode), this product also has the two modes PIN Controlled Mode and Security Mode. This section describes precautions for using the product in the PIN Controlled Mode and Security Mode.

## Publish Mode

### PIN Controlled Mode

In PIN Controlled Mode, only a publisher authenticated using the identity authentication function can publish a disc after the disc image and the label data file are created on the client computer. In addition, the disc that was published can be received only by a publisher who enters a user number and PIN to be certified as the person who published the disc.

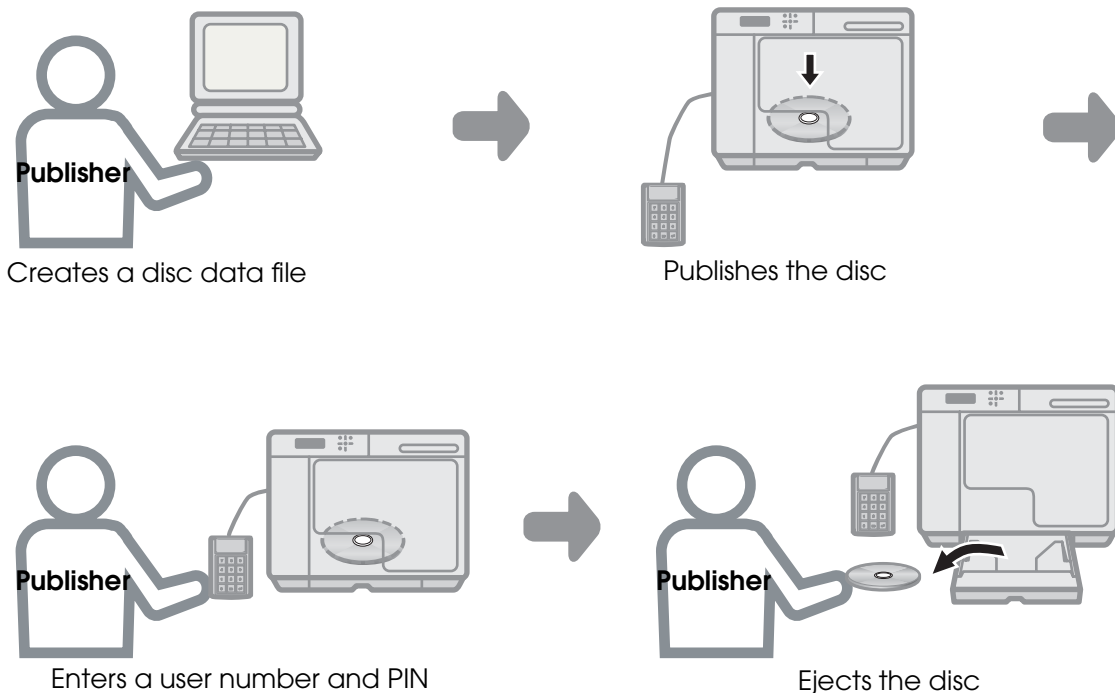

## Security Mode

In Security Mode, after the disc image and the label data file are created on the client computer, the publisher and the approver are authenticated using the identity authentication function, and the disc is published only if the correct approver approves disc publishing by the correct publisher using the approval workflow. In addition, the disc that was published can be received only by a publisher who enters a user number and PIN to be certified as the person who published the disc.

As a result, if you use Security Mode, published discs can no longer be passed to other people, which makes it possible to prevent data recorded on discs from leaking.

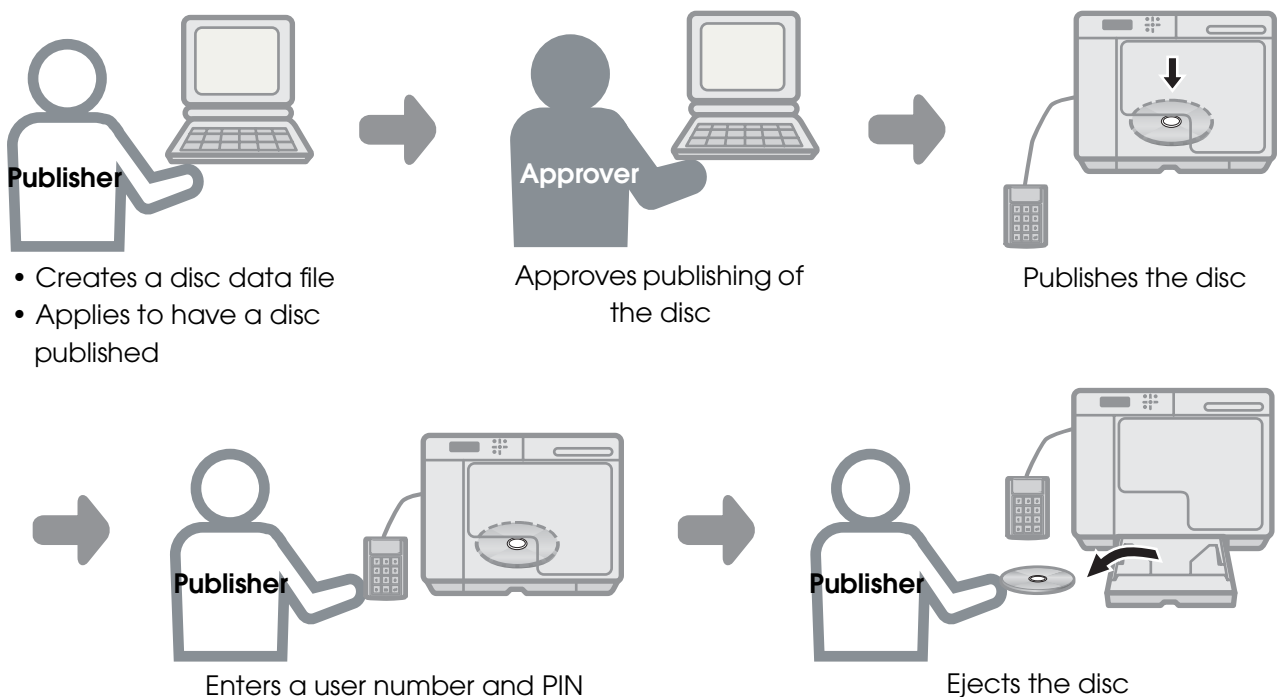

What this product (PP-100N) protects is the data on the published disc that is stored on this product. It does not protect the following data on this product.

- Source files on the file server or client computers as well as disc images and label data files
- Disc images and label data files saved on the hard disc of this product as pool data
- Data on a published disc that was ejected from this product or to Stacker 4

## Security control mechanisms

This product offers the following five security control mechanisms for implementing security functions that prevent leaks of data stored on your discs when you use the PIN Controlled Mode and Security Mode.

- **Controlled Distribution Function**

Only the user who created the disc can eject a published disc.

- **Electronic Lock Open Function**

Only administrators are permitted to unlock the disc cover.

- **Identity Authentication Function**

Only registered users are permitted to operate this product using the control panel and the Web application software included with the products (EPSON Total Disc Net Administrator), EPSON Total Disc Maker, and EPSON Total Disc Monitor.

- **Warning Function**

Issues a warning to the administrator when there is a possibility of a security breach.

- **Setting Data Control Function**

Only users with authority are permitted to access setting control data, job information, and disc position information.

## System configuration

The following items are required to use this product in Authentication Publish Option Mode.

### Hardware

- Client computers for approvers (only when in Security Mode), administrators, and publishers

### Software

- Total Disc Maker: Lets you write data to a disc, edit print data, and publish discs.
- Total Disc Setup: Lets you register the publish destination PP-100N.
- Total Disc Monitor: Shows the status of this product, and lets you show and change the status of a job.
- Internet Explorer 6/7: Used for EPSON Total Disc Net Administrator (Web application included with this product).

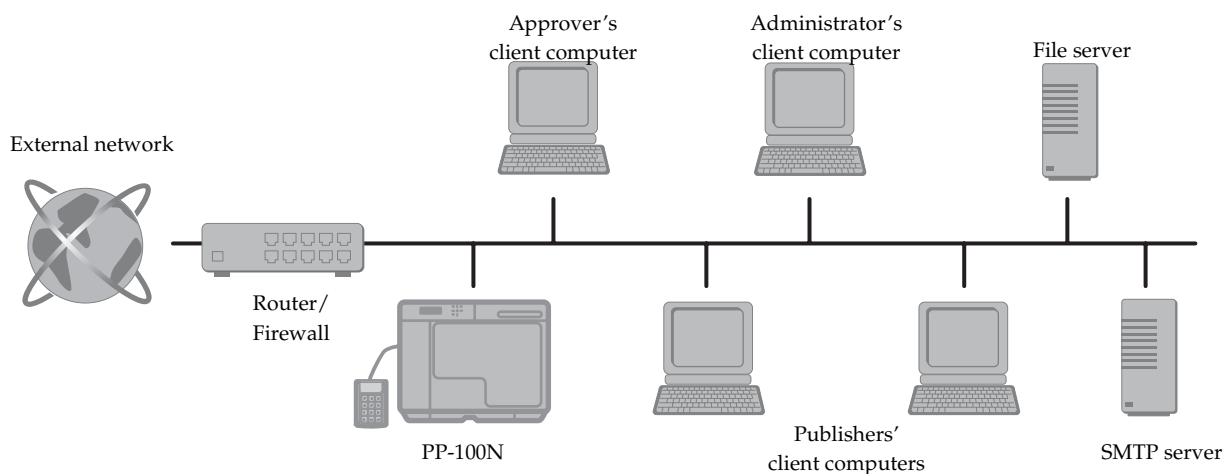

Note: It is necessary to be protected from the external network using a router or firewall.

Depending on the usage environment, an external network, SMTP server, or file server may not be present.

# Secure disc creation

To use the Pin Controlled Mode/Security Mode in this product and build an environment for creating disc securely, thoroughly familiarize yourself with the following information and start setup tasks.

## Roles of the person in charge and the users (administrators, approvers, publishers)

To appropriately use the Pin Controlled Mode/Security Mode in this product, it is necessary to separate the roles of the person in charge and the users (administrators, approvers, publishers). (In PIN Controlled Mode, it is not necessary to appoint an approver.) Each of the roles is described below.

---

### Who is the person in charge?

This is the head of the organization that installed this product.

#### Role of the person in charge

- Appoints administrators (more than one) who can be trusted and teaches the administrators the required knowledge
- Appoints approvers who can be trusted

---

### Who is a user?

A user is a person who has the authority to create discs using this product. This includes administrators, approvers and publishers.

More details about the work performed by users are presented in the *PP-100N Security User's Guide*.

#### Role of an administrator

- Sets up, operates, and manages this product
- Trains approvers and publishers in how to install the software
- Trains approvers and publishers in how to operate the product
- Responds when there is a possibility of a breach of security

More information about the work that administrators perform is presented in this guide.

#### Role of an approver

- Approves the creation of discs

More information about the work that approvers perform is presented in Approving/ Rejecting Job Applications in the *PP-100N Security User's Guide*.

#### Role of a publisher

- Creates discs
- Applies for creation of discs (Security Mode only)

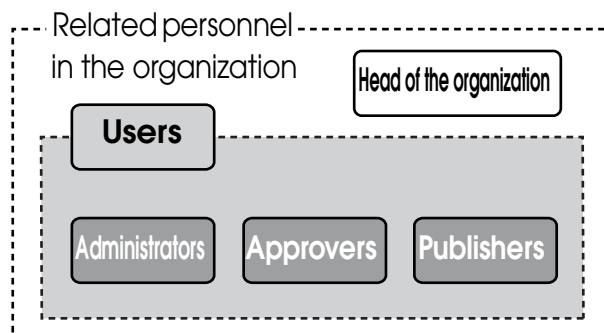

## *What is a secure disc creation environment?*

There is a risk of information leaks in environments where appropriate conditions are not met. Check the following issues.

- The person in charge must appoint people who can be trusted to be administrators and approvers (Security Mode only).
- People with knowledge of IT must be appointed as administrators.
- Several administrators who can always monitor the status of this product and who can respond quickly if a warning or error occurs must be appointed.
- Administrators must sufficiently understand the information in this guide in advance.
- Users themselves should manage user authentication information (passwords and PINs) used for identity authentication so that it is not used by third parties.
- Administrators must manage disc cover keys very carefully so that they are not used by anyone other than administrators.
- Measures such as making firewall and router security settings must be implemented so that this product is not subject to an attack from an external network.
- Measures must be taken to protect the data that flows within the internal network from hacking so that user authentication information (passwords and PINs), JOB data, and other information is not leaked.
- Measures must be taken to monitor the network so that the NTP server or DNS server is not falsified.
- An administrator must be present when a third party other than an administrator, such as a service engineer, sets up the product or changes the settings.

# Preparation

## Installation

Install this product in a suitable location with adequate space.



### CAUTION

- **Make sure that the product is lifted by two people.**

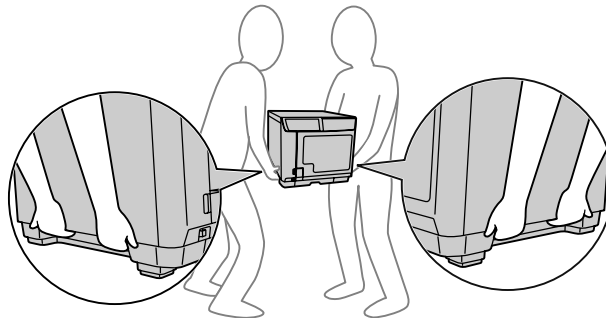

- The weight of this product is approximately 25.0 kg. When this product is lifted, it should be lifted on both sides by two people holding the recesses on the sides as shown in the illustration on the left. Holding any part other than the ones indicated in the illustration on the left when carrying the product may result in damage to the product. In particular, carrying the product while the disc cover, ink cartridge cover, or Stacker 4 is open may result in the product being dropped, or deformed and damaged. Furthermore, when putting down this product, take care not to trap a finger between the product and installation surface.
- **When lifting this product, make sure that, for example, you sufficiently bend your knees and your posture is such that excessive stress is not placed on your body.**  
An unnatural posture when lifting the product may result in an injury, or the product being damaged.
- **When moving the product, do not tilt it 10 or more degrees in a forward or backward direction, or sideways direction.**  
The dropping or other mishandling of the product may result in an accident.
- **Do not place a heavy object on the top of the product.**  
Subjecting this product to excessive force may result in a malfunction. However, it is possible to place one unit of this product on top of another. In such a case, make sure the tops and bottoms are oriented the same, and the exterior of the units are aligned.  
**Take sufficient care to prevent a unit from dropping or falling. Also, do not place more than one unit on top of another.**



- In a location where static electricity is easily generated, use an antistatic mat and other product to prevent static electricity.
- Do not install this product in locations with large amounts of dust, dirt, or cigarette smoke.
- Do not use or store in high-temperature, high-humidity environments. This can cause the label surfaces to blur and stick together.

## Installation location requirements

Install this product in the following type of location.

- Flat, stable location that can fully support the product weight (approx. 25.0 kg)
- Location that is wide enough to fully hold the product base
- Location where the air vents on the product are not blocked
- Location where the product is not subjected to vibrations or jolts
- Location where the product has access to its own dedicated power outlet
- Location that allows disc loading and unloading
- Location with sufficient space for attaching accessories, replacing consumables, and enabling regular maintenance and care
- Location that satisfies the following requirements

Temperature	Operation: 10 to 35°C, Storage: -20 to 40°C (Less than one month if at 40°C)
Humidity	Operation: 20 to 80% RH, Storage: 5 to 85% RH (no condensation)

## Installation space

Provide enough installation space for facilitating the installation work. If you place the product by the wall, leave more than 10 cm between the back of the product and the wall. It is also necessary to leave enough space in front of the product to open and close the disc cover.

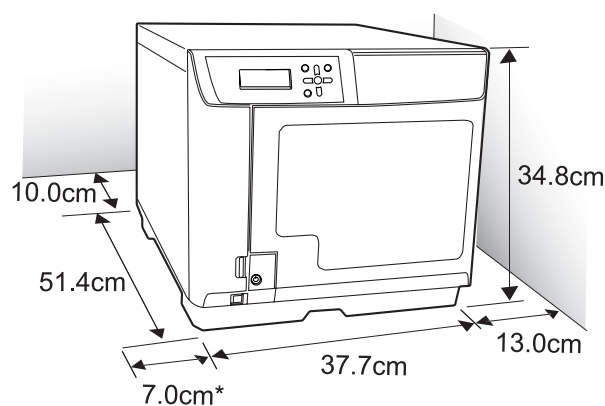

\* Be sure to leave at least 7 cm on the product left side for opening the ink cartridge cover.

# Setup procedure

This section describes the setup procedure for this product (PP-100N).



Before starting setup, check that all protective tape and protective materials attached to this product have been removed. See *PP-100N Security Setup Guide* for the procedure to remove the protective materials.

**1. Connecting the authentication keypad on page 21 in this guide**



**2. Connecting the Ethernet cable on page 25 in this guide**



**3. Connecting the power cord on page 25 in this guide**



**4. Installing the ink cartridges on page 26 in this guide**



**5. Setting the security lock switch on page 30 in this guide**



**6. Setting the Publish Mode on page 31 in this guide**



**7. Network settings on page 36 in this guide**



**8. Registering an administrator on page 42 in this guide**



**9. System settings on page 47 in this guide**



**10. Installing digital certificates on page 56 in this guide**

After setup of this product is complete, install the software required for using this product to the client computer. See the *PP-100N Security User's Guide* for details on the installation procedure.

**Notes**

If you are using more than one unit of this product in the same environment and back up the first unit and then restore the backup data on the second and subsequent units, the configuration information of the first unit is saved, so you do not need to perform the following work. See "Backing up and restoring data" on page 104 in this guide for details on the backup and restoration procedure.

- "Output device settings" on page 47 in this guide
- "Notification email transmission settings" on page 50 in this guide
- "Registering users" on page 79 in this guide

## Connecting the authentication keypad

Connect the authentication keypad for entering the user number and PIN during the authentication process.



Always use one of the following USB keypads as the authentication keypad.

- AKP09EU (Targus)
- KP25B (Micro Innovations)

- 1 Remove the two screws on the rear side that secure the top plate.

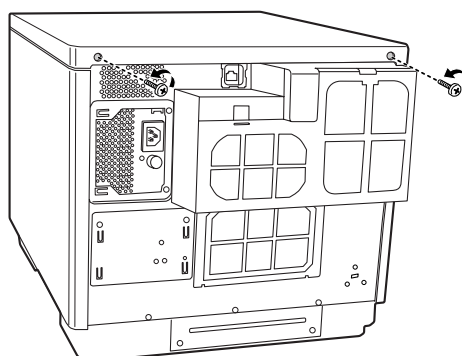

- 2 Open the disc cover.

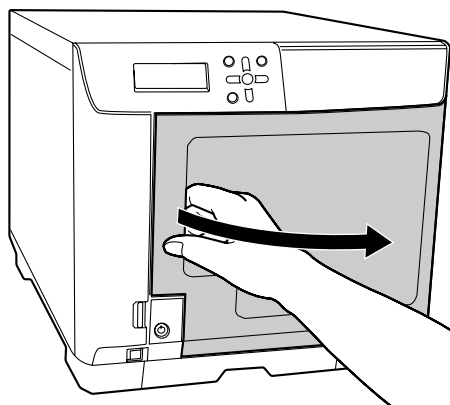

**3** Grasp the fixture on the top plate, and slide the top plate backwards slightly.

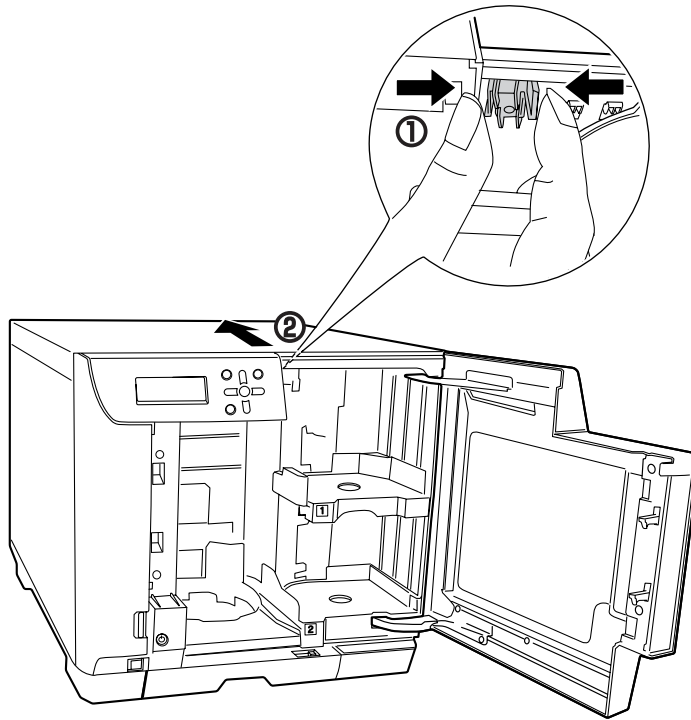

**4** Remove the top plate.

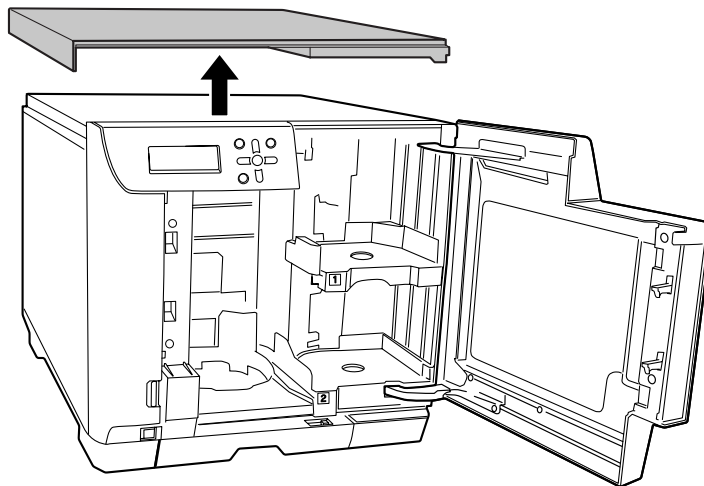

- 5 Remove the four screws on the rear side, and then remove the air vent cover.

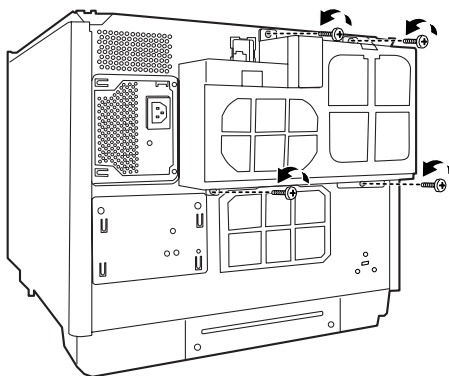

- 6 Connect the authentication keypad to the USB interface connector.

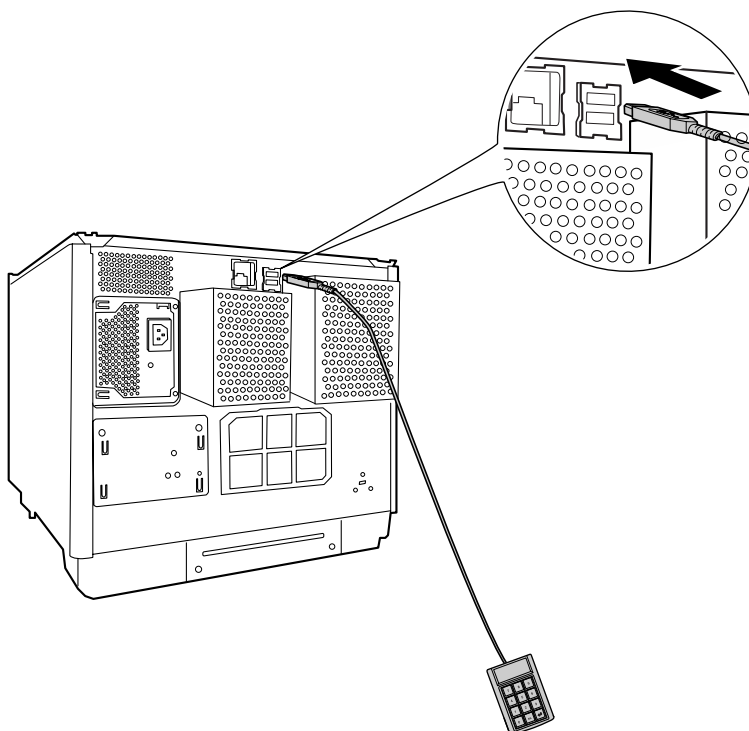

**Notes**

Two USB interface connectors are provided. The keypad can be connected to either one, but only one authentication keypad can be connected.

- 7** Pass the cord of the authentication keypad through the notched hole in the air vent cover, and then reattach the air vent cover using the four screws.

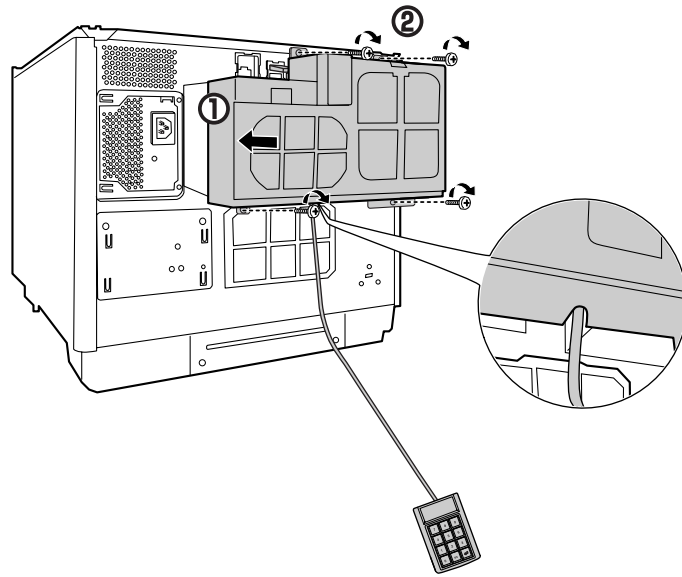

- 8** Mount the top plate, and secure in place using the two screws.
- 9** Close the disc cover.

## Connecting the Ethernet cable

Connect the Ethernet cable to the Ethernet interface connector on the rear side.

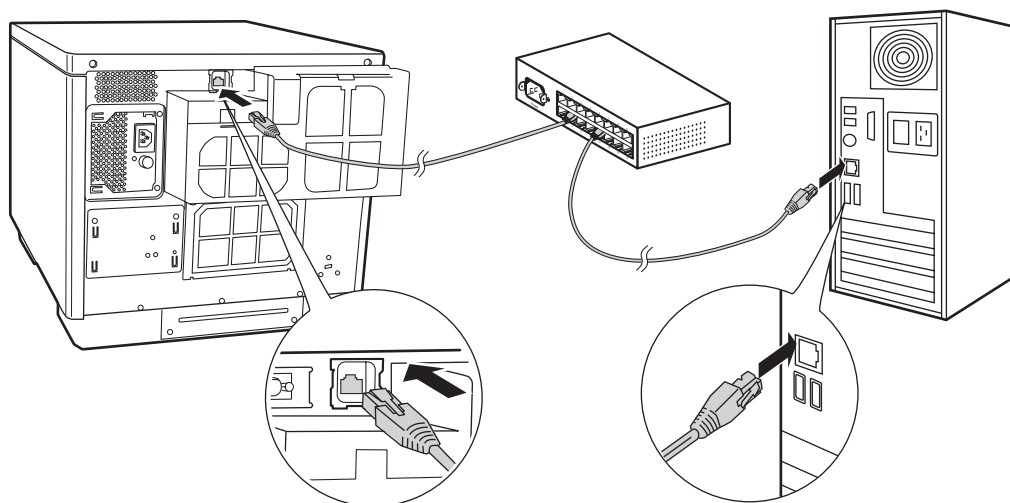

## Connecting the power cord

- 1 Connect the power cord connector to the AC inlet on the product rear side. (See (1) in the figure below.)
- 2 Insert the power plug into the outlet. (See (2) in the figure below.)

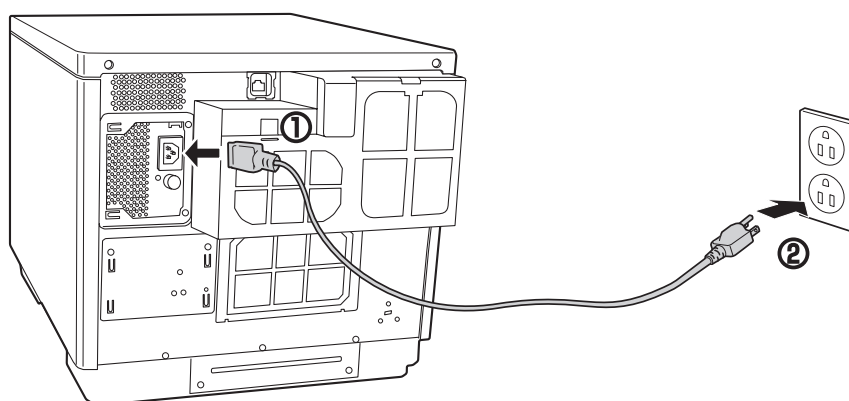

# Installing the ink cartridges

This section describes the procedure for installing the ink cartridges for the first time.

See “Changing the ink cartridge” in the *PP-100N Security User’s Guide* for the procedure to change the ink cartridge in daily operation.



- Use of Epson brand ink cartridges is recommended. Use of non-Epson brand ink cartridges can result in problems that will not be covered by the warranty.
- Epson cannot guarantee the quality and reliability of non-Epson brand products. Repairs for any damage or breakdown of this product due to the use of non-Epson brand products will not be free of charge even if the warranty period is still valid.
- This product performs color adjustment based on use of Epson brand ink cartridges. Use of non-Epson brand ink products can adversely affect the printing quality and prevent the product from realizing its maximum performance.
- The ink level for non-Epson brand ink products is not displayed in the printer driver or other indicators.
- Do not store ink cartridges in environments exposed to high temperatures, freezing temperatures, or to direct sunlight.
- Even when Black is selected in the printer driver, all the ink colors are used in an operation designed to maintain the printing and print head quality.

- 1 Open the ink cartridge cover by pressing the knob at the bottom right of the cover.

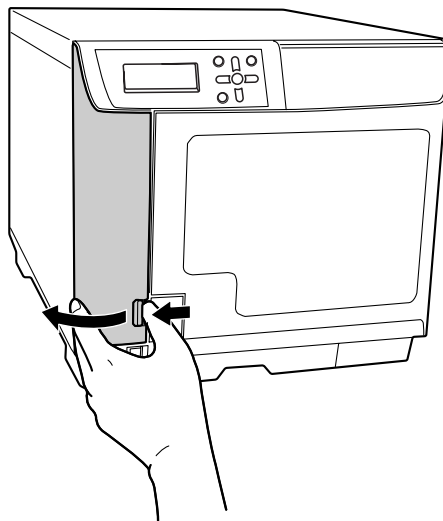

## 2 Remove the ink cartridge from its package.

- The first time you install ink cartridges, use the ink cartridges supplied with the product or use ink cartridges in which there is a sufficient amount of ink remaining.
- For optimum printing quality, do not open the transparent plastic package until immediately before installation. Also, after opening the package, try to use it up within six months. Using an ink cartridge that has been left opened for an extended period of time can result in poor printing quality.
- When opening the plastic package, be careful that the ink cartridge does not drop. This could cause the ink to leak.
- Do not place the ink cartridge with the ink supply holes facing downward. This could cause stains on a desk or other surface. Also, dust and other substances can adhere to the ink cartridge so that it does not function properly.
- Do not shake the ink cartridges too hard. The ink cartridges may leak if you shake them around too much.
- Do not touch the green chip section attached to the ink cartridge. Also, never peel off the labels and film affixed to the ink cartridge. This could prevent proper installation, operation, or printing with the ink cartridge, and cause a leak.

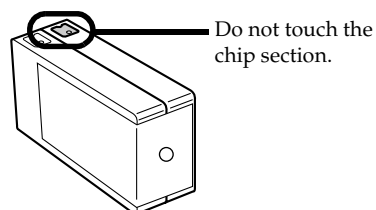

- Try to use up the ink cartridge by the validity date printed on the individual package.

## 3 Insert all six color ink cartridges into the ink cartridge holders by gently pressing them in until they click into place.

Check the label color of the ink cartridge and the label color of the ink cartridge holder, and install the ink cartridge in the same color position.

Press  section of the ink cartridge, and push straight in firmly.

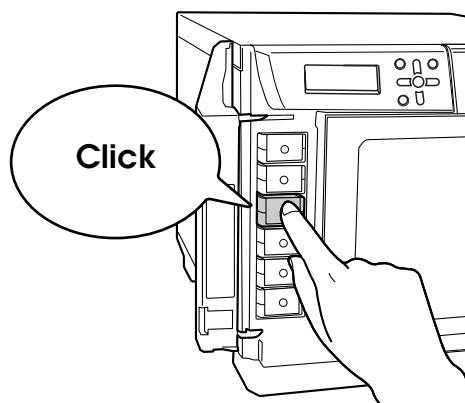

Install all six ink cartridges. If any of the colors is not installed, disc publishing (writing/printing) cannot be performed.

**4** Close the ink cartridge cover.

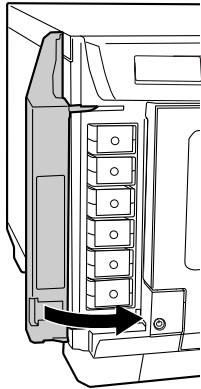

**5** Press the power button to turn on the power.  
The Power LED flashes, and ink filling (loading ink) is started.

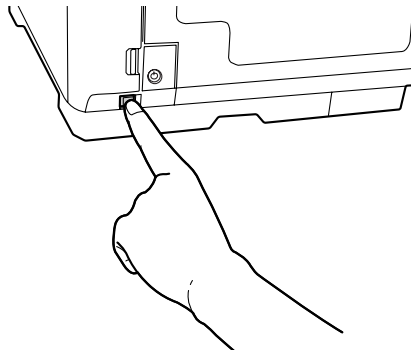



- When using for the first time, the product operates to prepare the internal components of the product (loading ink).
- While ink is being loaded (approximately 5 minutes), do not turn off the power or open the ink cartridge cover. These actions would make it necessary to perform the loading ink operation again, resulting in the consumption of a substantial amount of ink. Also, printing may be unable to be performed properly.
- In the initial loading ink operation immediately after purchase, the ink is filled up to the tip sections of the print head nozzles (ink discharge holes) to enable printing, and so ink equivalent to this amount is consumed. As a result, the quantity that can be printed is higher when the ink cartridges are installed from the second time.
- If the ink cartridges are not recognized even though they are installed correctly, dust or another object may be adhering to the green chip surface. Use a soft cloth to wipe off the object, and then reinstall the cartridge.
- If printing cannot be performed properly even though the ink cartridges are installed, perform head cleaning. See “Head cleaning” in the *PP-100N Security User’s Guide* for details on the head cleaning procedure.
- When the power is turned off using the power button on the main unit, the print head is automatically capped to prevent drying of the ink. After the ink cartridge is installed, be sure to use the power button on the main unit to turn off the power whenever the product is not used. Do not disconnect the power plug or shut off the circuit breaker while the power is still on.
- If moving or transporting the product after the ink cartridges are installed, leave them installed during the moving or transporting process.
- The ink cartridges should only be removed when replacing them.

**Notes**

When the ink cartridges are installed for the first time (during setup), ink is consumed for filling (loading ink), and so the ink cartridge will need to be replaced earlier than normal.

## Setting the security lock switch

Set the security lock switch for automatically locking the disc cover. In the initial state, the security lock switch is set to off.

- 1 Open the disc cover.

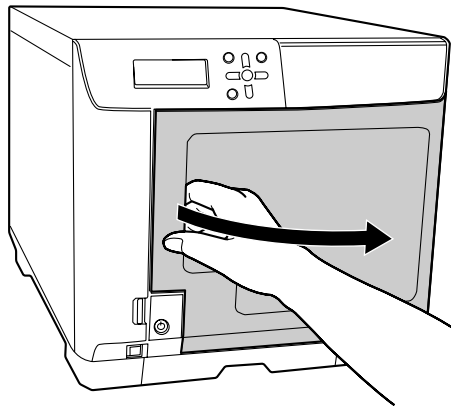

- 2 Set the security lock switch to on.

When set to on, the disc cover is locked automatically each time it is closed. To unlock the lock, use the disc cover key or operate the control panel.

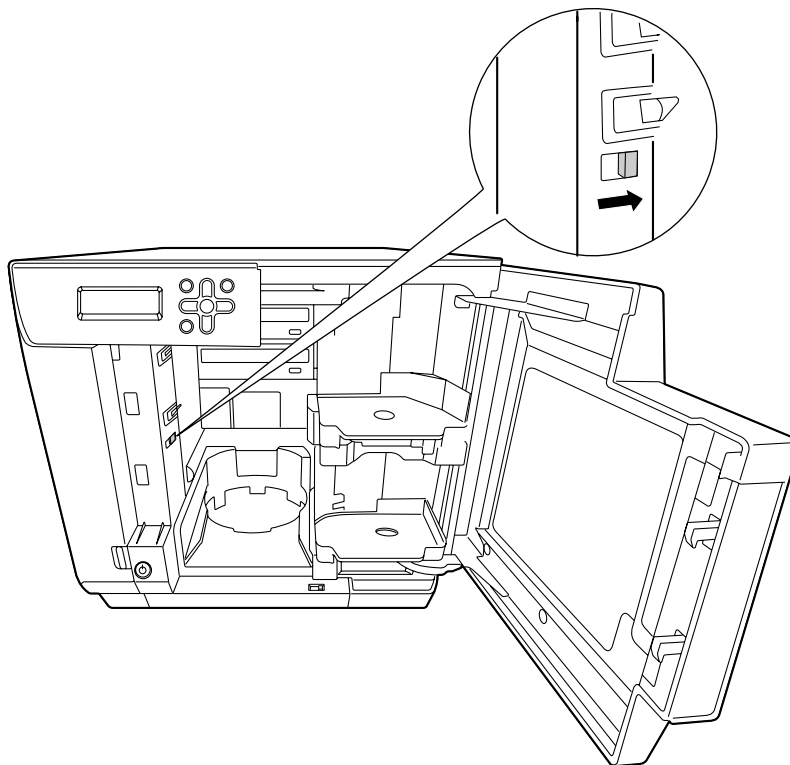

When the security lock switch is set to off, the disc cover is always unlocked. Be sure to set the security lock switch to on when using in the PIN Controlled Mode/Security Mode.

# Setting the Publish Mode

Select the Publish Mode to be used from PIN Controlled Mode and Security Mode, mount the stackers, and set the Publish Mode.

## Types of Publish Modes

### PIN Controlled Mode

The published disc is temporarily stored in Stacker 2, and when the user number and PIN are entered, the publisher of the disc only can take out the disc from Stacker 4.

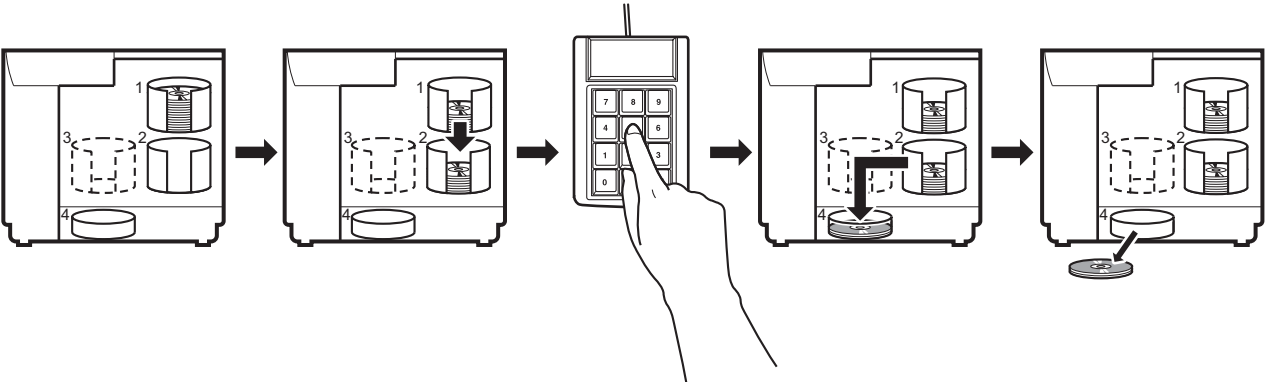

### Security Mode

The approval workflow is used to perform identity authentication of the publisher and approver so that approved discs only are published. The published disc is temporarily stored in Stacker 2, and when the user number and PIN are entered, the publisher of the disc only can take out the disc from Stacker 4.

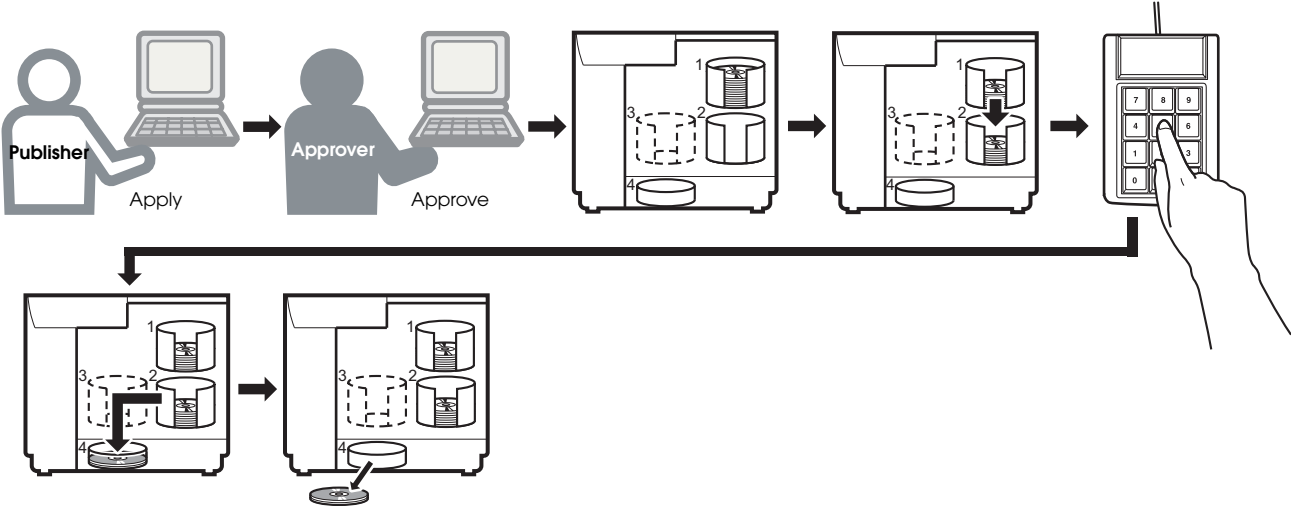

## Installing the stackers

After the Publish Mode is determined, use the procedure below to install the stackers for the selected mode.

- 1 Insert Stacker 1 by aligning with the recesses.

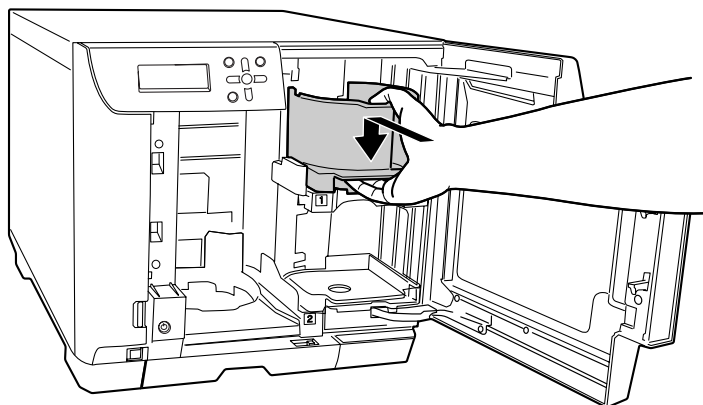

- 2 Insert Stacker 2 by aligning with the recesses.

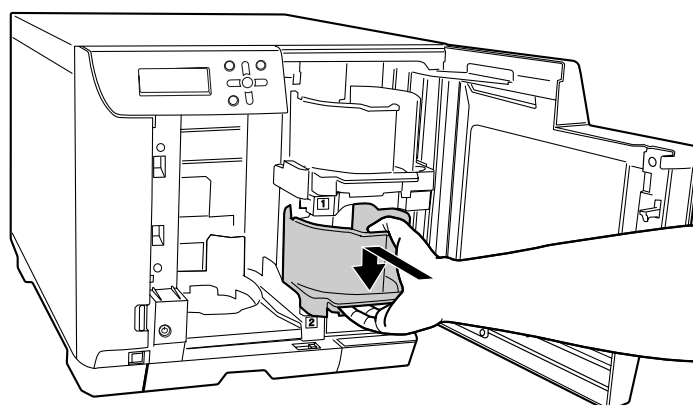

- 3 Set the lock lever to the [UNLOCK] position.

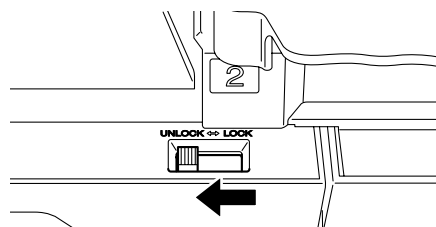

Stacker 3 is not used in PIN Controlled Mode/Security Mode.

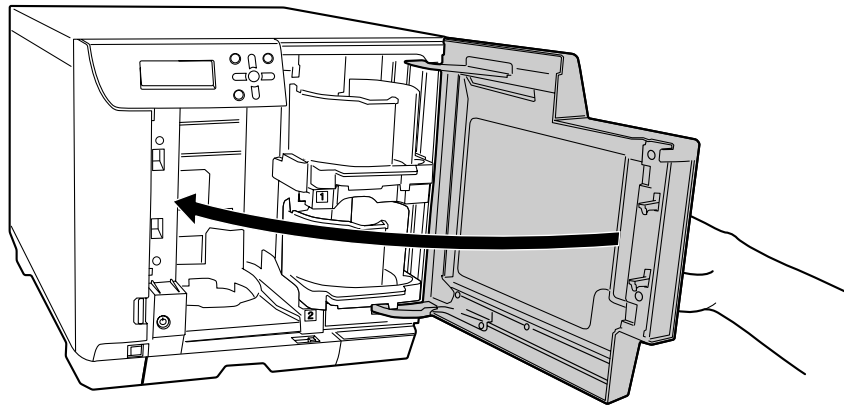
**4** Close the disc cover.

## Setting procedure

After installing the stackers, use the procedure below to set the Publish Mode.



Before setting the Publish Mode, be sure to check that the authentication keypad is connected, the ink cartridges and stackers are installed, the security lock switch is set to on, and the lock lever is in the (UNLOCK) position.

- 1 Check that the disc cover is locked.
- 2 In the mode selection screen displayed on the LCD, press the EJECT button three times, and then press the MENU button.

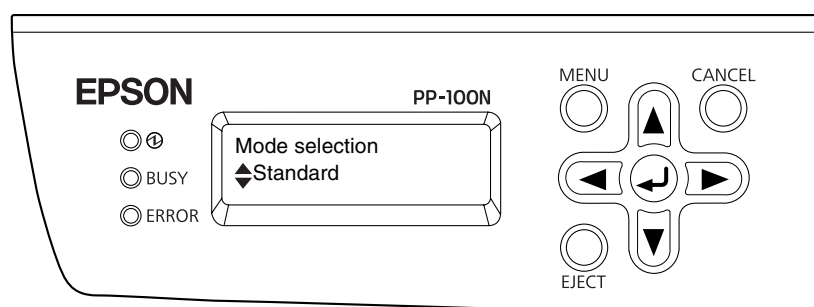

- 3 Use the ▲/▼ buttons to display the mode to be used, and press the ↵ button.

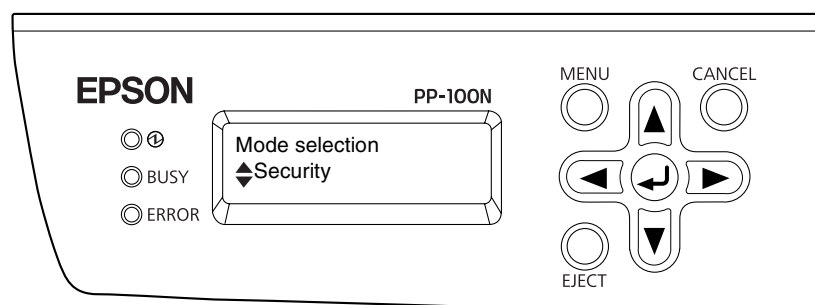

- 4 When the confirmation message appears, press the ↵ button.

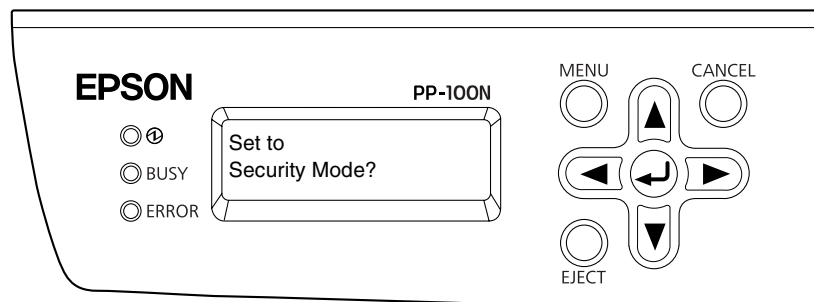

The initialization operation begins. Initialization takes two to three minutes.  
When initialization is finished, [Please register an administrator] appears on the LCD.



- Never turn the power off during initialization.
- An administrator needs to be registered to use this product. After you finish configuring the network settings (see page 36 in this guide), be sure to register an administrator. See “Registering an administrator” on page 42 in this guide for the procedure for registering an administrator.
- The operation of this product differs depending on the Publish Mode setting. To prevent the occurrence of an unexpected warning or error, check that the correct Publish Mode has been set after you set or change the Publish Mode.
- If the Security Mode is set, be sure to check the TOE version after setting. See “Checking the TOE version (Security Mode only)” on page 114 in this guide for the procedure to check the TOE version.

**Notes**

After you set the Publish Mode, you can change the language setting for messages displayed on the LCD of this product from English to Spanish, French, Italian, Dutch, Portuguese, Japanese, or German. See “Setting the language” on page 62 in this guide if you want to change the language setting.

# Network settings

The network can be set in the following two ways.

- Performing an operation from a PC
- Performing an operation with the product's control panel

When performing the setup for the first time, carry out the network setup using the control panel.

## Notes

The network settings cannot be made using a computer until an administrator is registered. See page 42 in this guide for the procedure to register the administrator.

## Performing an operation with the product's control panel

- 1 Press the MENU button.  
The top menu appears.
- 2 Use the ▲/▼ buttons to display the Network settings ("Top menu Network") screen, and press the ◀ button.

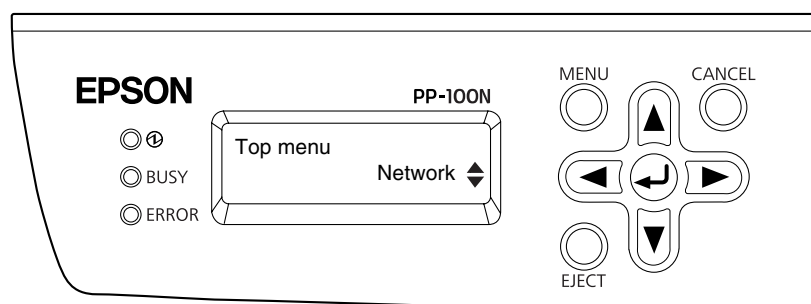

- 3 Use the ▲/▼ buttons to display the change settings ("Network Change settings") screen for the network, and press the ◀ button.

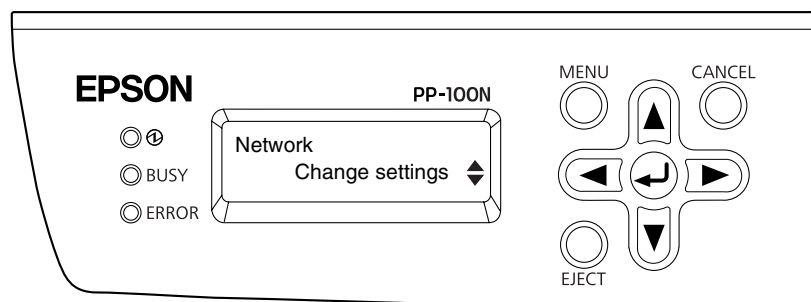

4 Use the authentication keypad to enter the user number; then press the Enter key.

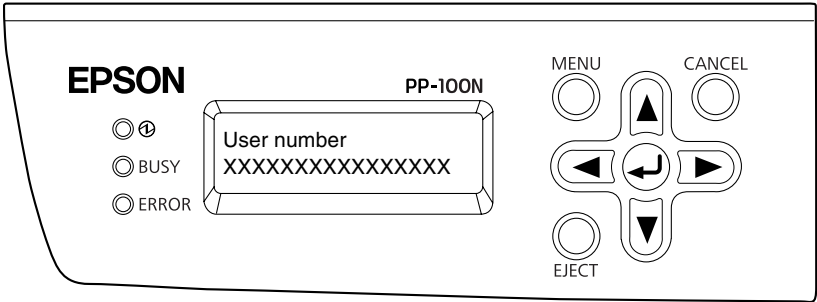

 If an administrator is not registered, no screen is displayed asking for input of the user number and PIN.

5 Use the authentication keypad to enter the PIN, and press the Enter key.

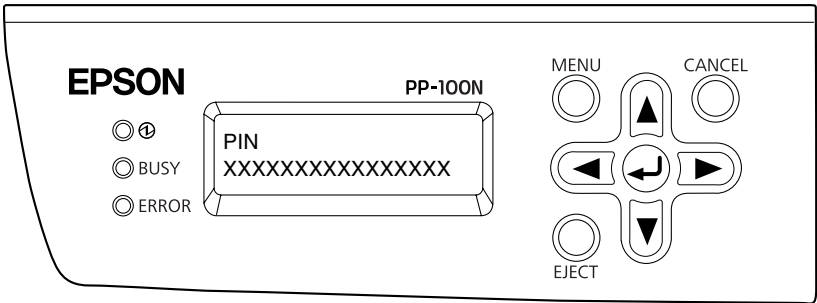

6 Use the ▲/▼ buttons to display the change settings (“Change settings IP address”) screen for the IP address, and press the ↵ button.

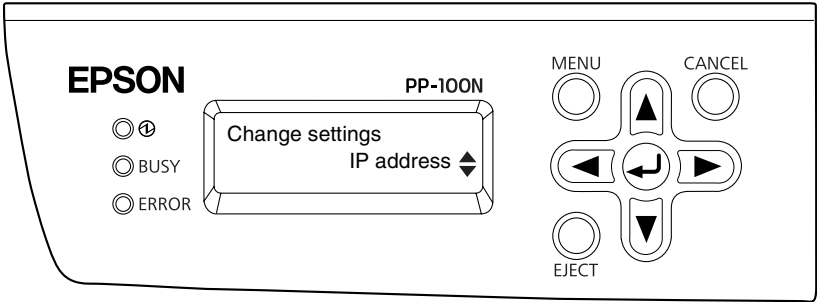

7 Use the ▲/▼ buttons to select the setting method, and press the ↻ button.

When "Manual" is selected: The settings are made manually. Proceed to step 8.

When "Auto" is selected: The network settings are made automatically by DHCP. Proceed to step 11.

When "Manual" is selected

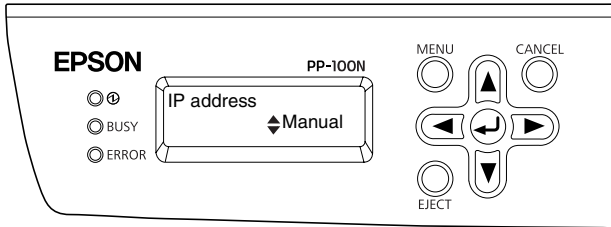

When "Auto" is selected

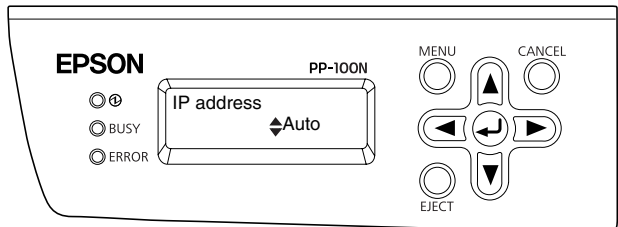

8 Use the ▲/▼/ ◀ / ▶ buttons to enter the IP address, and press the ↻ button.

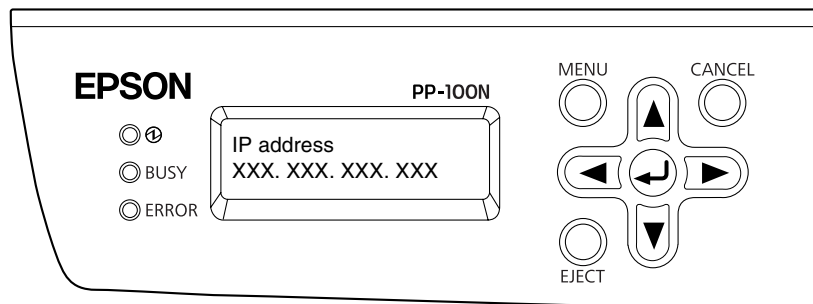

9 Use the ▲/▼/ ◀ / ▶ buttons to enter the subnet mask, and press the ↻ button.

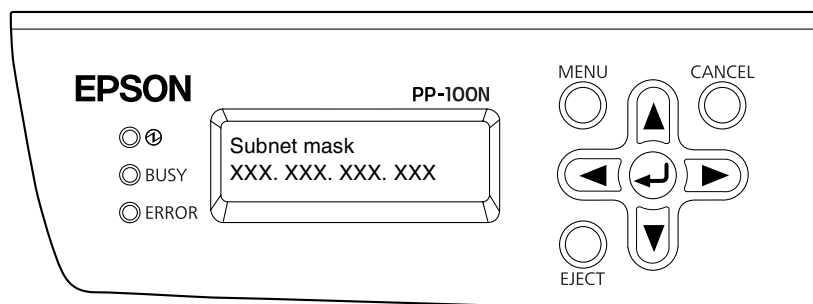

10 Use the ▲/▼/ ◀ / ▶ buttons to enter the default gateway, and press the ↵ button.

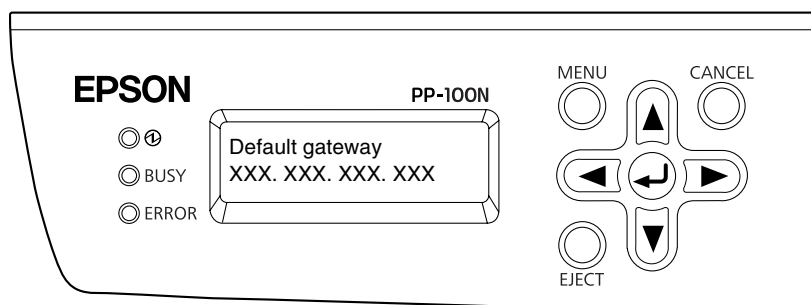

11 When the change setting confirmation message ("Change network settings?") appears, press the ↵ button.

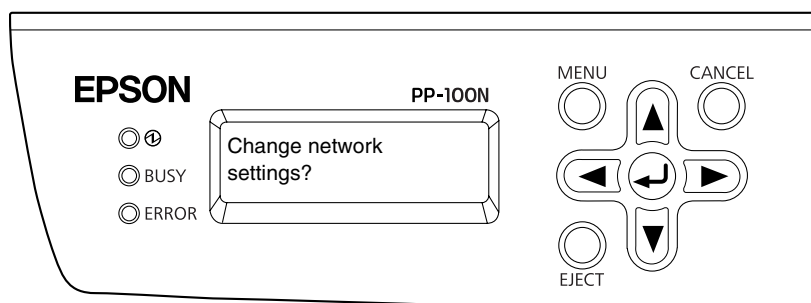

**Notes**

- If necessary, set the Jumbo Frame. ("Top menu" - "Network" - "Change Settings" - "JUMBO FRAME") In the initial state, Jumbo Frame is set to off.
- If (Receiving job Cannot proceed) appears on the LCD, wait until job processing is finished and then try again.

## Performing an operation from a PC

### Notes

- The network settings first become able to be set using a PC when an administrator is registered after the network settings have been set using the control panel. See page 42 in this guide for the procedure for registering an administrator.
- The link speed and Jumbo Frame cannot be set using a PC. Use this product's control panel ("Top menu" - "Network" - "Change settings" - "Link speed/JUMBO FRAME").

- 1 Log in to EPSON Total Disc Net Administrator.  
See "Logging in to EPSON Total Disc Net Administrator" in the *PP-100N Security User's Guide* for the login procedure.
- 2 Click the [Network] tab in the [System settings] screen.

The screenshot displays the EPSON Total Disc Net Administrator interface. At the top, the "Disc producer" logo is on the left, and the user name "EpsonAdmin1" is on the right. Below the header is a navigation bar with tabs for "Job management", "User management", "System settings" (which is active), "Maintenance", "Certificate", and "Inspection log". Under the "System settings" tab, there are sub-tabs for "Output device", "Network" (which is selected and circled), "Email", and "Date/Time". The "Network" sub-tab contains several settings sections: "Device name" with a text input field containing "PP-100N-xxxxxx"; "Publish mode" with a "Mode" dropdown menu set to "Security Mode"; "Stacker 1" with a dropdown menu set to "CD-R"; "Stacker 2" with a dropdown menu set to "Output stacker"; "Drive settings" with a "Drive used" dropdown menu set to "Use both" and a "Number of write retries" dropdown menu set to "0" with the unit "time(s)"; and "Printer settings" with a checked checkbox for "Show error mark on discs that experience errors". A "Save" button is located at the bottom right of the settings area.

- 3 Either manually enter the IP address, DNS server setup method, and host and domain name setup method, or set them to [Auto], and click [Save].

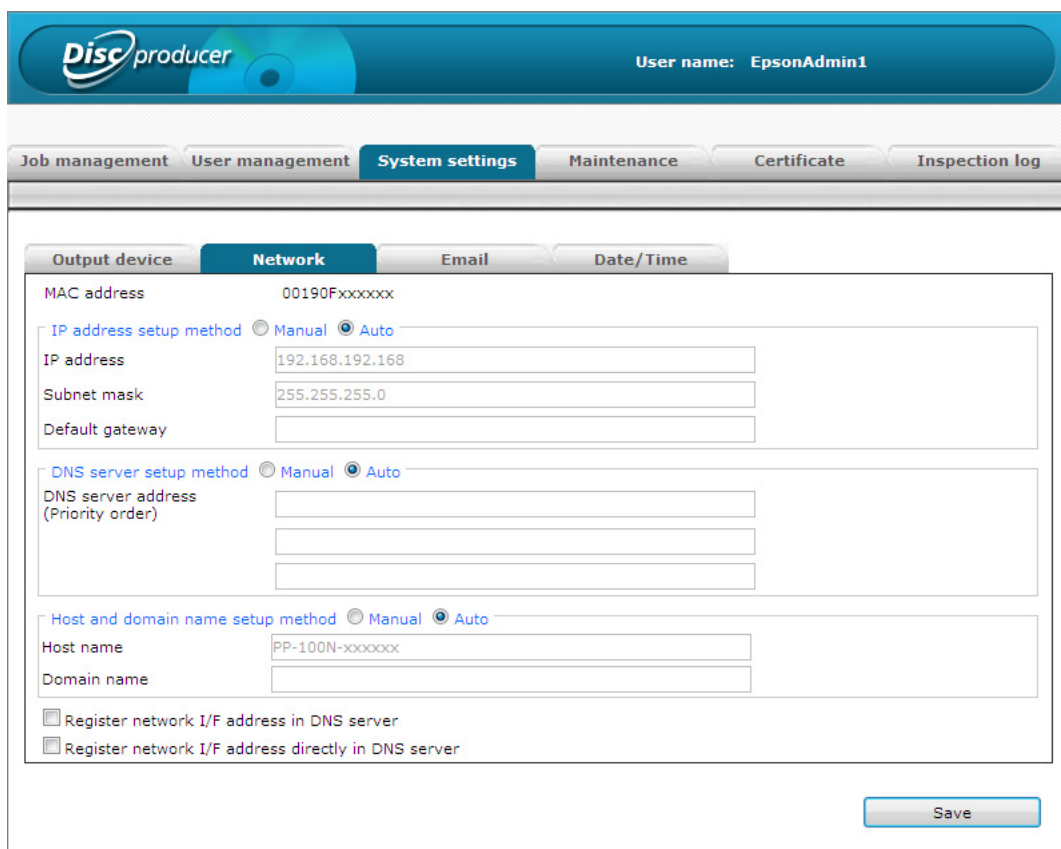

The screenshot shows the Discproducer web interface. At the top, the logo "Discproducer" is on the left and "User name: EpsonAdmin1" is on the right. Below the header is a navigation bar with tabs: "Job management", "User management", "System settings" (selected), "Maintenance", "Certificate", and "Inspection log". Under "System settings", there are sub-tabs: "Output device", "Network" (selected), "Email", and "Date/Time". The "Network" tab contains the following fields and options:

- MAC address: 00190Fxxxxxx
- IP address setup method:  Manual  Auto
- IP address: 192.168.192.168
- Subnet mask: 255.255.255.0
- Default gateway: (empty)
- DNS server setup method:  Manual  Auto
- DNS server address (Priority order): (empty)
- Host and domain name setup method:  Manual  Auto
- Host name: PP-100N-xxxxxx
- Domain name: (empty)
- Register network I/F address in DNS server
- Register network I/F address directly in DNS server

A "Save" button is located at the bottom right of the form.

- 4 Click [OK].

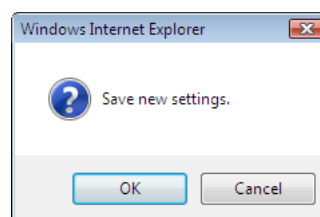

# Registering an administrator

Register an administrator who will administer and manage the product. After registering the administrator, other users who will use the product can be registered. (See “Registering users” on page 79 in this guide for the procedure to register the user.)



- Two or more administrators must be assigned to monitor the product’s status constantly and to be able to respond quickly when a warning or error occurs.
- In Security Mode, the administrator who is registered first is also registered as the approver.

**1** Start Internet Explorer on the computer, and enter the IP address (<https://xxx.xxx.xxx.xxx>) that was set for the product into the address bar.

In this example, we enter <https://192.168.192.168>.



- In the PIN Controlled Mode or Security Mode, enter “https” instead of “http” in order to perform encrypted communication.
- The IP address setting can be checked with the product’s control panel (“Top menu” – “Network” – “Check settings”).

**2** Click [Continue to this website (not recommended).] if a security warning screen appears.

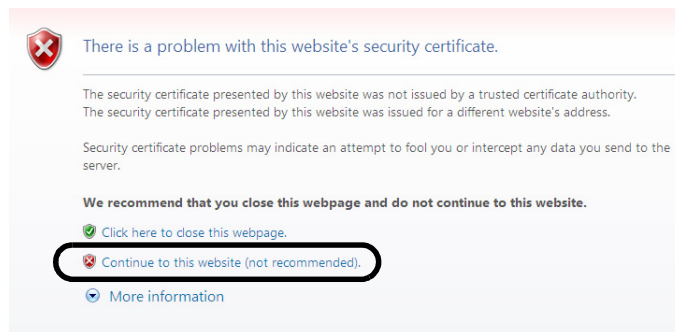

After the CA certificate is imported, the security warning screen is not displayed. See “Installing digital certificates” on page 56 in this guide for the procedure to import the CA certificate.

- 3 Enter the activation key, and click [OK].

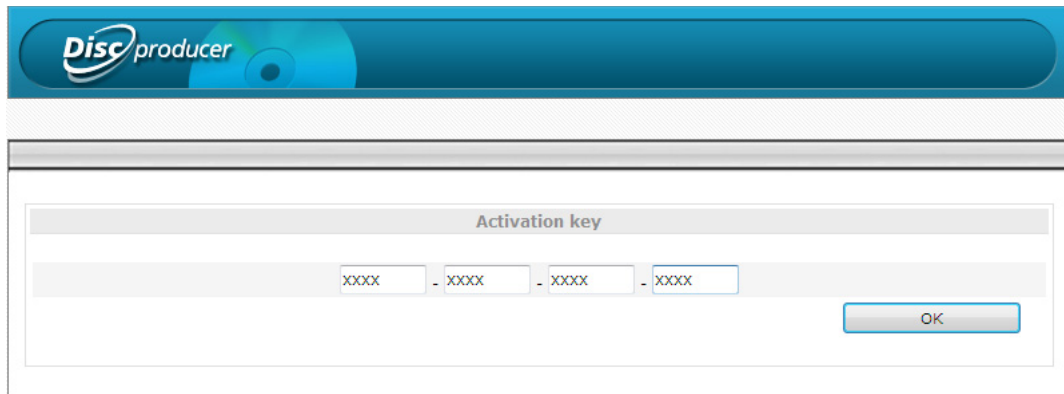

The screenshot shows the 'Disc producer' software interface. At the top, there is a blue header with the 'Disc producer' logo and a CD icon. Below the header, there is a window titled 'Activation key'. Inside this window, there is a text input field containing 'xxxx - xxxx - xxxx - xxxx'. To the right of the input field is an 'OK' button.

**Notes** Refer to the sheet supplied with the product for the activation key.

4 Enter the information for each item, and click [Save].

The screenshot shows a web-based user registration form for 'Disc producer'. The form is titled 'User registration' and contains the following fields:

- User name\***: EpsonAdmin1
- Password\***: [masked with dots]
- Confirm password\***: [masked with dots]
- Full name**: [empty]
- Email address**: [empty]
- Authority**:  Approver  Administrator
- User number\***: 2559030
- PIN\***: [masked with dots]
- PIN confirmation\***: [masked with dots]

\*are required fields.

Save

- **User name:** Enter the user name to use for identity authentication in EPSON Total Disc Maker/EPSON Total Disc Monitor/EPSON Total Disc Net Administrator.
- **Password:** Enter the password to use for identity authentication in EPSON Total Disc Maker/EPSON Total Disc Monitor/EPSON Total Disc Net Administrator.
- **Confirm password:** Enter the password again for confirmation.
- **User number:** Enter the user number to use for performing identity authentication with the authentication keypad.
- **PIN:** Enter the PIN to use for performing identity authentication with the authentication keypad.
- **PIN confirmation:** Enter the PIN again for confirmation.



- Enter 5 to 16 alphanumeric characters for the user name.
- Enter 5 to 16 alphanumeric characters or symbols (".", "-", "\_") for the password.
- The password is case-sensitive.
- Do not set a date of birth, employee number, or anything else that is easy to guess for the password or PIN.
- Enter 5 to 16 numbers for the user number and PIN.
- Manage the password and PIN so that they cannot be used by anyone other than the user.
- The period of validity for the password and PIN is 180 days. Change them regularly before the period of validity ends. (See "Changing password and PIN" on page 89 in this guide for the procedure to change the password and PIN).
- When there are only 30 days left until the period of validity for the password and PIN expires, a message appears to notify you that the period is to expire soon each time you log in to EPSON Total Disc Net Administrator.
- If notification email transmission is set, when there are only 30 days left until the period of validity for the password and PIN expires, an email is sent to notify the user that the period of validity is to expire soon.

**Notes**

- Enter a full name and email address if necessary. An email address needs to be entered if notification email transmission is set. See "Notification email transmission settings" on page 50 in this guide for details on the notification email transmission settings.
- See "Registering users" on page 79 in this guide for details on registration of the second and subsequent administrators.

## 5 Click [OK].

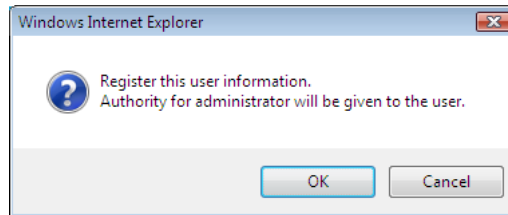

After registration of the administrator is completed, the administrator is automatically logged in to EPSON Total Disc Net Administrator, and the top screen ([Job management] screen) is displayed.

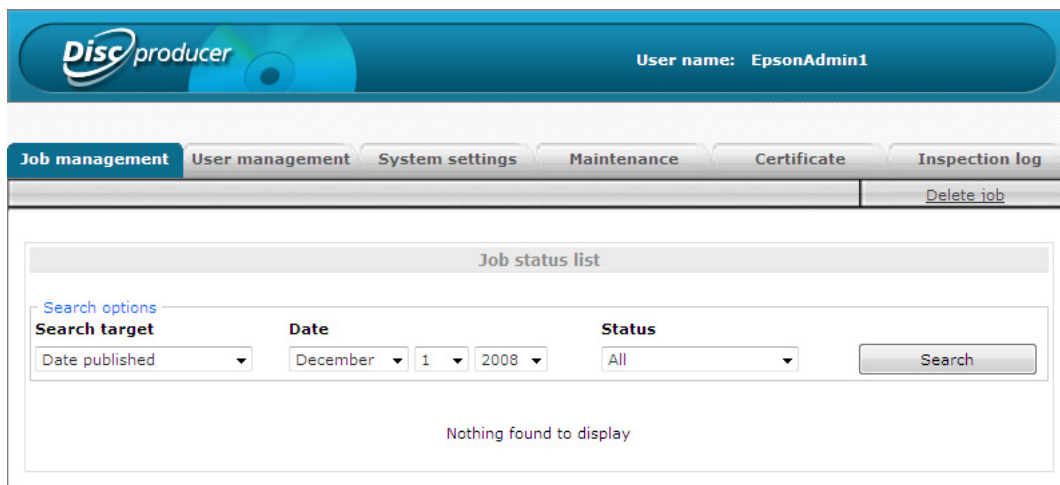

### Notes

Clicking the (User management) tab displays the user list where you can check that the administrator is registered correctly.

- Clicking (Edit) allows you to change the full name and email address of the administrator.
- In this case, clicking (Delete) does not delete the user information because only one administrator is registered. At least one administrator must be registered at all times.

# System settings

Make the settings to match the usage purpose and operating environment of the product.

## Output device settings

This is used to select the type of disc that is used, make the drive settings, and make the settings when a write error occurs.

- 1 Log in to EPSON Total Disc Net Administrator.  
See "Logging in to EPSON Total Disc Net Administrator" in the *PP-100N Security User's Guide* for the login procedure.
- 2 Click the [System settings] tab.

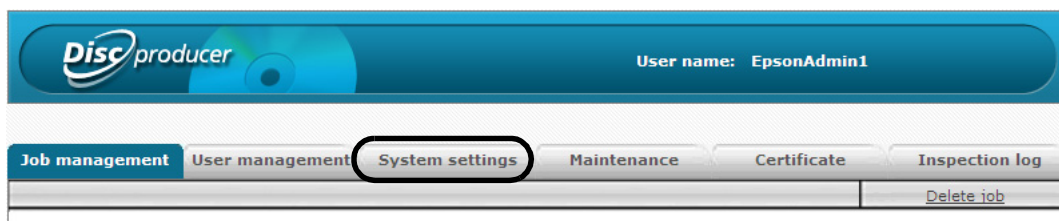

- 3 Set the information for each item, and click [Save].

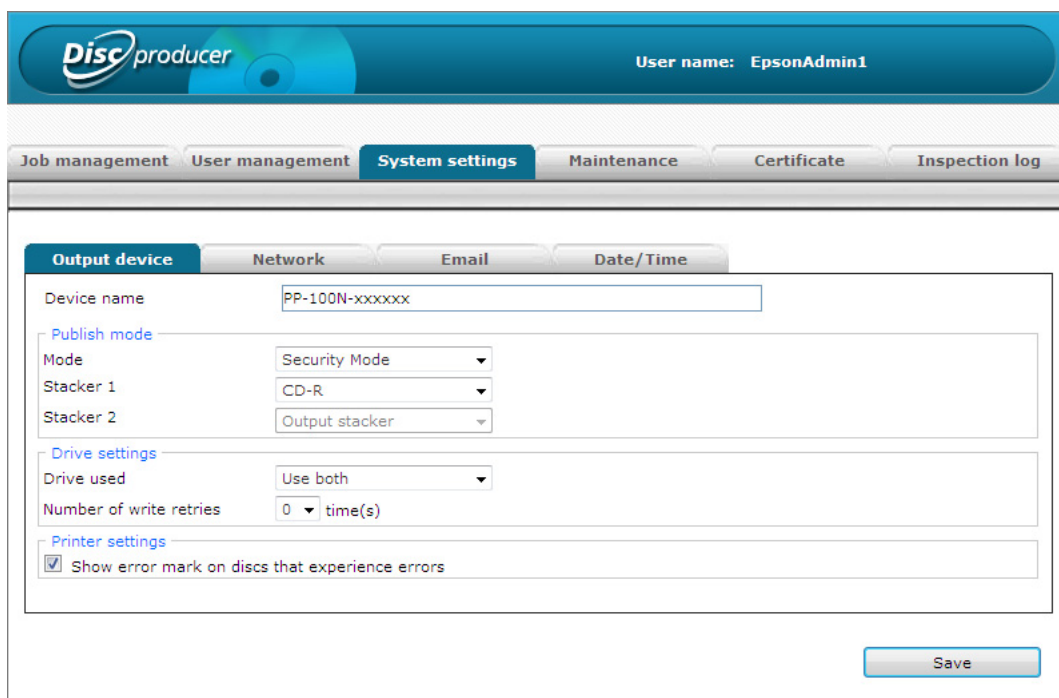

*Device name: The name of the connected product can be set.*

### *Publish Mode*

- **Mode:** This displays the Publish Mode that was set. The Publish Mode can also be changed. (See “Changing the Publish Mode” on page 97 in this guide.)
- **Stacker 1:** Select the type of disc that is used from the list below.  
CD-R, DVD-R 4.7GB, DVD-R DL 8.5GB, DVD+R 4.7GB, DVD+R DL 8.5GB
- **Stacker 2:** [Output stacker] is displayed

### *Drive settings*

- **Drive used:** Select the drive that will be used from the drives below.

<b>Item</b>	<b>Description</b>
Use both	Both Drive 1 and Drive 2 are used to write the disc. Jobs will be efficiently processed by using two drives. If trouble occurs on either drive and it cannot write data, the other drive will be used automatically.
Use Drive 1 Only	Use only Drive 1
Use Drive 2 Only	Use only Drive 2

- **Number of write retries:** The number of write retries after an error occurs during disc writing is selected from zero to nine.

#### **Notes**

- Setting the number of write retries enables a job to be executed again without job processing pausing even if an error occurs during writing. The error disc is output to Stacker 2.
- When a write error occurs based on a preset number of write retries, use of the drive is automatically stopped, and (Drive operation paused DRV1/2) is displayed on the LCD. To resume use of the stopped drive, make the setting at (Drive Settings).
- See “Disc writing problems” on page 127 in this guide for details on the causes and remedy procedures for write errors.

### *Printer settings*

- **Show error mark on discs that experience errors**

If you check this check box, an error mark will be printed on any disc with a write error. This is useful to identify the disc which encountered the write error.

#### **Notes**

- The error mark will not be printed in the following cases.
- The job was cancelled in the EPSON Total Disc Monitor.
  - Not enough ink was left to print the error mark
  - Fatal error

4 Click [OK].

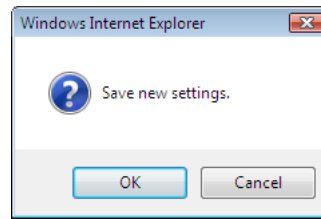

## Notification email transmission settings

Settings can be made for sending emails which pertain to disc publishing and approval workflow, notify when the ink must be replaced, or notify about problems that have occurred.



- When a notification email is received, measures must be taken by following the instructions contained in the email.
- An email address must be set to receive a notification email. See “Registering users” on page 79 in this guide or “Checking user information” on page 78 in this guide for the procedure to set the email address.
- If spam blocking software is used, change the settings so that the email containing the URL sent from the email address set in (Sender’s email address) can be received.

### Notes

If you want to cancel the notification email transmission settings (see page 52 in this guide) after setting them, clear the (SMTP server) field in the (Email) screen, and then save the settings. The other input values of the mail settings are automatically cleared and the settings are saved.

## Notification email types

The following types of notification email can be sent.

### *Emails pertaining to disc publishing*

- Emails notifying when a job is completed (to publisher)
- Emails notifying that the input stacker is empty (to administrator)
- Emails notifying that the input stacker is full (to administrator)
- Emails notifying that written discs are loaded to the input stacker (to administrator)
- Emails notifying that a different disc type than that specified for the job is loaded to the input stacker (to administrator)
- Emails notifying that a write error has occurred on the disc (to administrator)

### *Emails pertaining to the approval workflow (Security Mode only)*

- Emails notifying when a job application was made (to approver/proxy approver)
- Emails notifying when a job application was canceled by the administrator (to publisher)
- Emails notifying when a job application was denied by the approver or proxy approver (to publisher)

### *Emails pertaining to ink*

- Emails notifying when it is nearly time to change an ink cartridge (to administrator)
- Emails notifying when it is time to change an ink cartridge (to administrator)
- Emails notifying when it is nearly time to change the ink pad (to administrator)
- Emails notifying when it is time to change the ink pad (to administrator)

### *Emails pertaining to security*

- Emails notifying that the period of validity of the password has nearly expired (to user)
- Emails notifying that a published disc was remaining inside the product when the power was turned on. (to administrator)

- Emails notifying that the disc cover has been left open for 60 seconds (to administrator)
- Emails notifying that the disc cover has not been locked even though 10 seconds have elapsed since it was closed, or the disc cover was not locked when the power was turned on (to administrator)
- Emails notifying that the power cannot be turned off due to a specific cause (to administrator)
- Emails notifying that a user account has been locked (to administrator)
- Emails notifying that the previous power off sequence was not performed properly (to administrator)

And so on

### *Emails pertaining to hardware*

- Emails notifying that disc transfer has failed (to administrator)
- Emails notifying that opening or closing of the printer tray or drive has failed (to administrator)
- Emails notifying an internal error has occurred in the autoloader, printer, or drive (to administrator)
- Emails notifying that a printer maintenance error has occurred (to administrator)

And so on

<Example of a notification email>

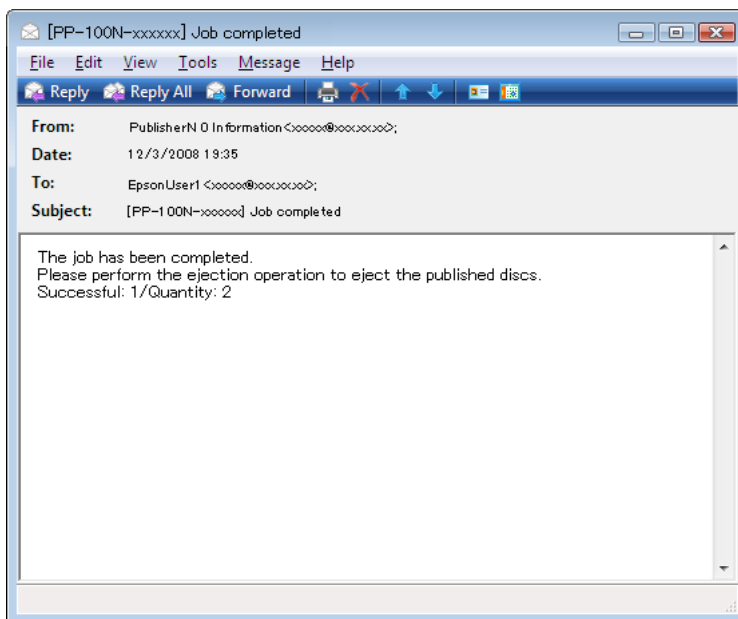

## Setting procedure

Use the procedure below to make the notification email settings.

- 1 Log in to EPSON Total Disc Net Administrator.  
See “Logging in to EPSON Total Disc Net Administrator” in the *PP-100N Security User’s Guide* for the login procedure.
- 2 Click the [Email] tab in the [System settings] screen.

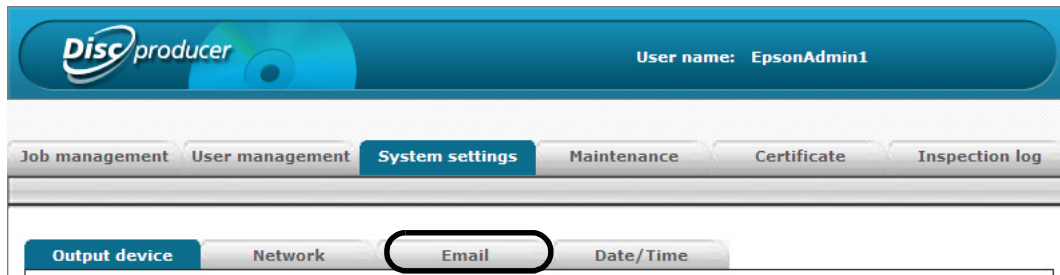

- 3 Set the information for each item, and click [Save].

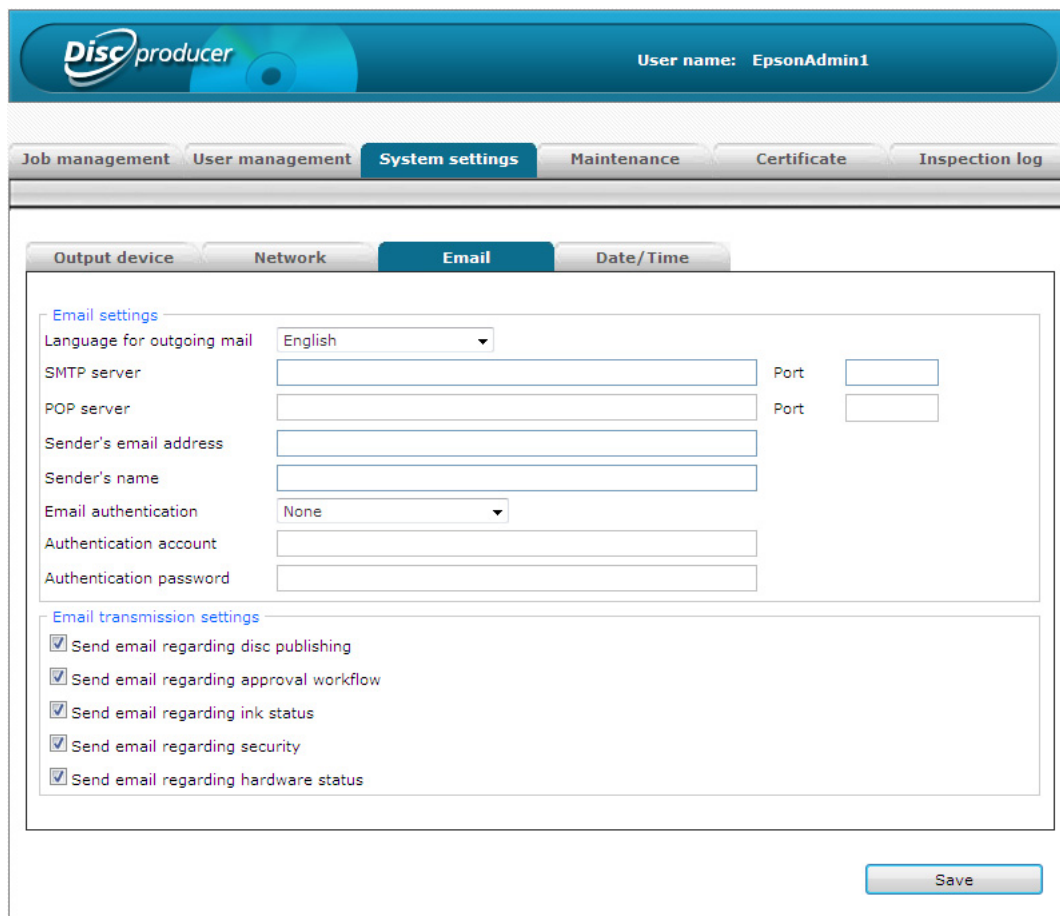
The screenshot shows the 'Email' sub-tab selected in the 'System settings' screen. The 'Email settings' section contains the following fields:

- Language for outgoing mail: English (dropdown menu)
- SMTP server: [text input] Port: [text input]
- POP server: [text input] Port: [text input]
- Sender's email address: [text input]
- Sender's name: [text input]
- Email authentication: None (dropdown menu)
- Authentication account: [text input]
- Authentication password: [text input]

The 'Email transmission settings' section contains the following checked checkboxes:

- Send email regarding disc publishing
- Send email regarding approval workflow
- Send email regarding ink status
- Send email regarding security
- Send email regarding hardware status

A 'Save' button is located at the bottom right of the form.

### *Email settings*

- Language for outgoing mail: Select the language to use in notification email from the languages below.  
Japanese, German, English, Spanish, French, Italian, Dutch, Portuguese
- SMTP server: Enter the IP address or host name and port number of the SMTP server that is used to send notification email.
- POP server: If [POP before SMTP] or [APOP before SMTP] is selected in [Email authentication], enter the IP address or host name and port number of the POP server that is accessed.
- Sender's email address: Enter the notification email address of the sender.
- Sender's name: Enter the sender name of the notification email.
- Email authentication: Select the notification email authentication method from the methods below.  
None, POP before SMTP, APOP before SMTP, SMTP-AUTH (PLAIN), SMTP-AUTH (LOGIN), SMTP-AUTH (Digest-MD5)
- Authentication account: Enter the authentication account of the email server.
- Authentication password: Enter the authentication password of the email server.

### *Email transmission settings*

Select the check boxes for the types of email that you want to send.

#### **4** Click [OK].

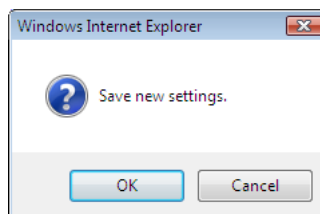

## Setting the date and time

This sets the product's internal clock.

- 1 Log in to EPSON Total Disc Net Administrator.  
See "Logging in to EPSON Total Disc Net Administrator" in the *PP-100N Security User's Guide* for the login procedure.
- 2 Click the [Date/Time] tab in the [System settings] screen.

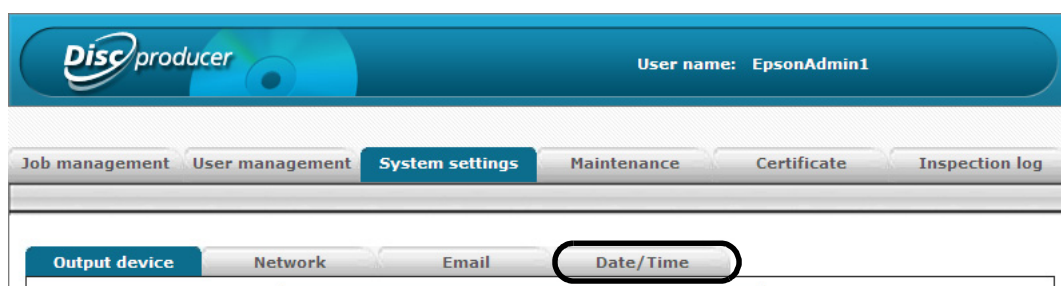

- 3 Select [Manual setting] or [Automatic setting].  
When [Manual setting] is selected: Select the date, and enter the time.  
When [Automatic setting] is selected: Select one of the NTP server setting methods below.
  - To set the NTP server manually, select [Manual], and enter the IP address or host name of the NTP server into [NTP server].
  - To set the NTP server from the DHCP server, select [Auto].

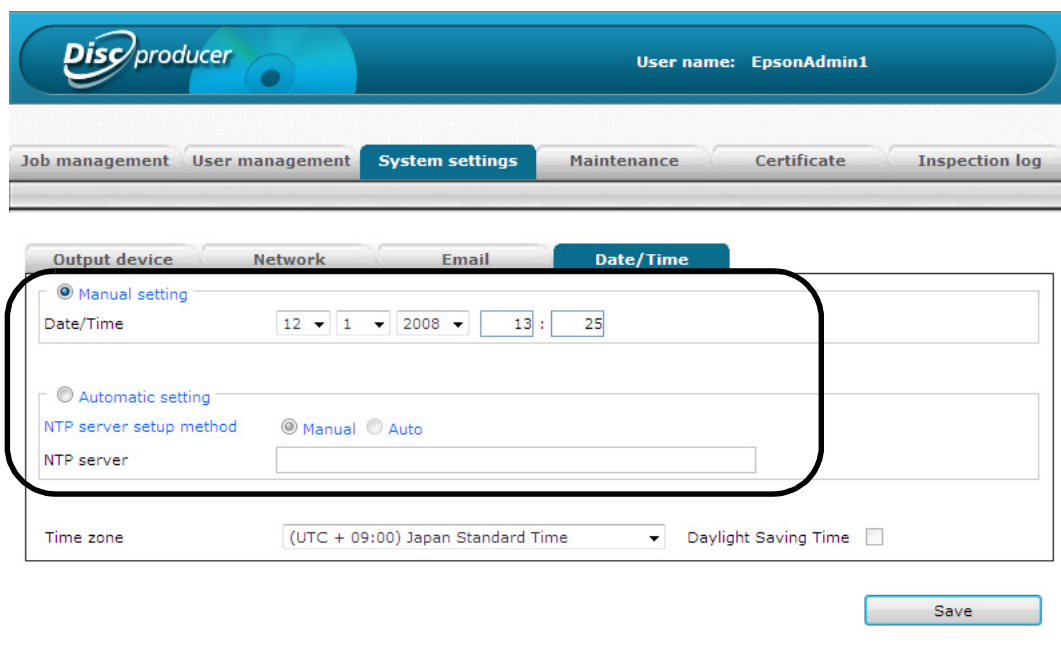

- 4 Select [Time zone], and if daylight saving time is used, select the check box for [Daylight Saving Time], and click [Save].

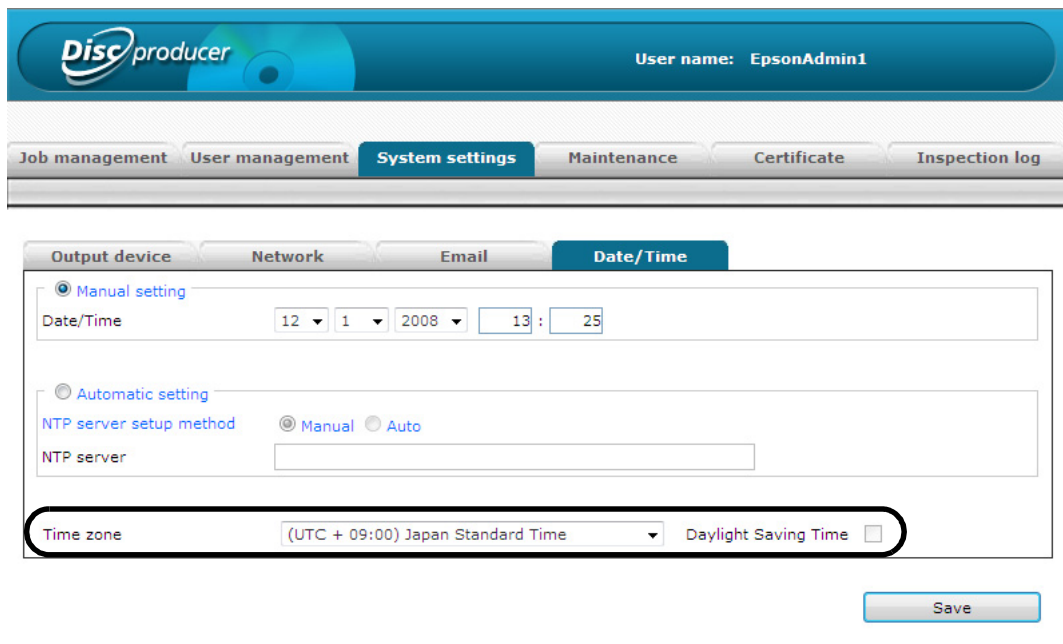

The screenshot shows the Discproducer web interface. At the top, the logo "Discproducer" is on the left and "User name: EpsonAdmin1" is on the right. Below the logo is a navigation bar with tabs: "Job management", "User management", "System settings" (selected), "Maintenance", "Certificate", and "Inspection log". Under "System settings", there are sub-tabs: "Output device", "Network", "Email", and "Date/Time" (selected). The "Date/Time" tab contains two sections: "Manual setting" and "Automatic setting". The "Manual setting" section has a "Date/Time" field with dropdowns for month (12), day (1), and year (2008), and input boxes for hour (13) and minute (25). The "Automatic setting" section has "NTP server setup method" with radio buttons for "Manual" (selected) and "Auto", and an empty "NTP server" text box. At the bottom of the "Date/Time" section, there is a "Time zone" dropdown menu set to "(UTC + 09:00) Japan Standard Time" and a "Daylight Saving Time" checkbox which is unchecked. A "Save" button is located at the bottom right of the form.

- 5 Click [OK].

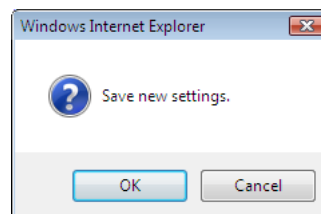

# Installing digital certificates

Installing digital certificates enables secure communication between the server (this product) and client computer. The digital certificate is installed by the administrator using the procedure below.

There are the following two ways of installing the digital certificate.

- When the certificate authority installed in the product can be trusted for use
- When a certificate authority is managed by the company or other organization

---

## ***When the certificate authority installed in the product can be trusted for use***

### *(1) Creating a CA certificate and server certificate*

Create a CA certificate and server certificate, and save them in the product.

See “Creating a CA certificate and server certificate” on page 57 in this guide for details on the creation procedure.

### *(2) Downloading the CA certificate*

Download the CA certificate for this product.

See “Downloading the CA certificate” on page 59 in this guide for details on the download procedure.

### *(3) Importing the CA certificate*

Import the CA certificate to the user’s client computer.

If the CA certificate is imported correctly, the security warning screen no longer appears when logging into the EPSON Total Disc Net Administrator.

---

## ***When a certificate authority is managed by the company or other organization***

### *(1) Downloading the server certificate*

The administrator downloads an unsigned server certificate from this product.

See “Downloading the server certificate” on page 60 in this guide for details on the download procedure.

### *(2) Signing the server certificate*

The certificate authority managed by the organization is used to sign the server certificate that was downloaded in (1).

Please ask the certificate authority administrator to perform the signing procedure, or refer to the operation manual of the certificate authority software.

### *(3) Uploading the server certificate*

Upload the server certificate that was signed in (2) to this product.

See “Uploading the server certificate” on page 61 in this guide for details on the upload procedure.

### *(4) Importing the CA certificate*

Import the CA certificate managed by the organization to the user’s client computer.

If the CA certificate is imported correctly, the security warning screen no longer appears when logging into the EPSON Total Disc Net Administrator.

## Creating a CA certificate and server certificate

Use the following procedure to create a CA certificate and server certificate.

- 1 Log in to EPSON Total Disc Net Administrator.  
See “Logging in to EPSON Total Disc Net Administrator” in the *PP-100N Security User’s Guide* for the login procedure.
- 2 Click the [Certificate] tab.

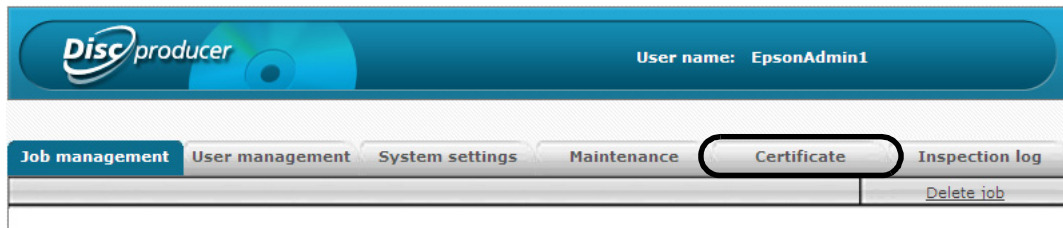

### 3 Enter the information for each item, and click [Issue].

Disc producer User name: EpsonAdmin1

Job management User management System settings Maintenance Certificate Inspection log

Certificate

Start of period of validity Dec 1, 2008

Period of validity 5 Year(s)

Country \* JP

Prefecture or state

City, town, or village

Organization \* Seiko Epson Corporation

Department \* Marketing Dept.

Issue to \* 192.168.192.168

\* are required fields.

Issue

- Start of period of validity: This displays the current date as the start date of period of validity.
- Period of validity: The period of validity of the certificate can be selected from 1 Year, 2 Years, 3 Years, 4 Years, or 5 Years.
- Country: Enter the country code (The country codes are specified in ISO3166.) written in the certificate using two alphanumeric characters.
- Prefecture or state: Enter the prefecture or state name written in the certificate using alphanumeric characters and symbols\*.
- City, town, or village: Enter the city, town, or village name written in the certificate using alphanumeric characters and symbols\*.
- Organization: Enter the organization name written in the certificate using alphanumeric characters and symbols\*.
- Department: Enter the department name written in the certificate using alphanumeric characters and symbols\*.
- Issue to: This displays the publish destination (IP address) to which the certificate is issued. The publish destination (IP address) can also be changed here.

\*Symbols: "-", ",", ".", "+", "/", "("")"



When you attempt to access EPSON Total Disc Net Administrator, a security warning screen appears if the product's IP address, host name, or FQDN entered in the Internet Explorer address bar differs from that of (Issue to).

### 4 Click [OK].

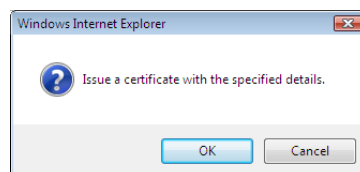

The CA certificate and server certificate that were created are saved in the product.

## 5 Turn off the product.

The saved CA certificate and server certificate are valid when the power for the product is turned on the next time.

### Downloading the CA certificate

Use the following procedure to download the CA certificate.

- 1 Log in to EPSON Total Disc Net Administrator.  
See “Logging in to EPSON Total Disc Net Administrator” in the *PP-100N Security User’s Guide* for the login procedure.
- 2 Click the [Certificate] tab.

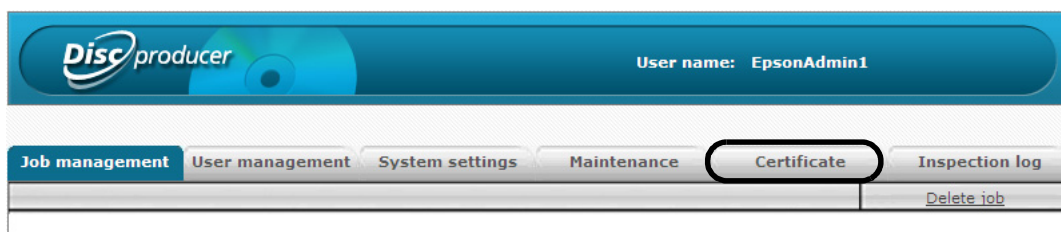

- 3 Click [Download] in [Download CA certificate].

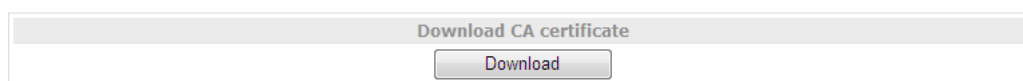

- 4 Specify the save location for the certificate file, and then save the certificate file.

## Downloading the server certificate

Use the following procedure to download the server certificate.

- 1 Log in to EPSON Total Disc Net Administrator.  
See “Logging in to EPSON Total Disc Net Administrator” in the *PP-100N Security User’s Guide* for the login procedure.
- 2 Click the [Certificate] tab.

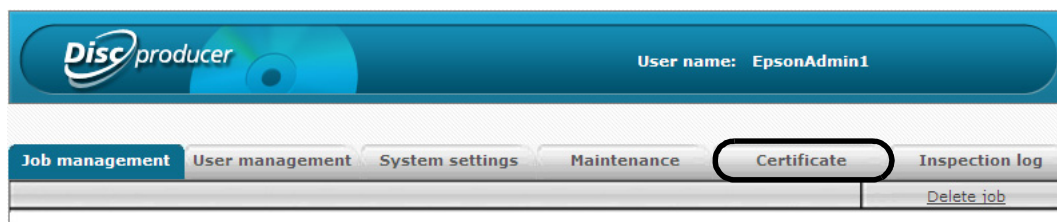

- 3 Click [Download] in [Download server certificate].

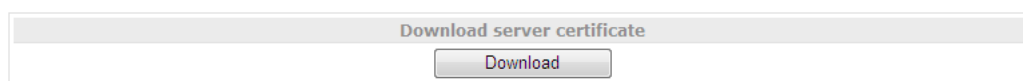

- 4 Specify the save location for the certificate file, and then save the certificate file.

## Uploading the server certificate

Use the following procedure to upload the server certificate.

- 1 Log in to EPSON Total Disc Net Administrator.  
See “Logging in to EPSON Total Disc Net Administrator” in the *PP-100N Security User’s Guide* for the login procedure.
- 2 Click the [Certificate] tab.

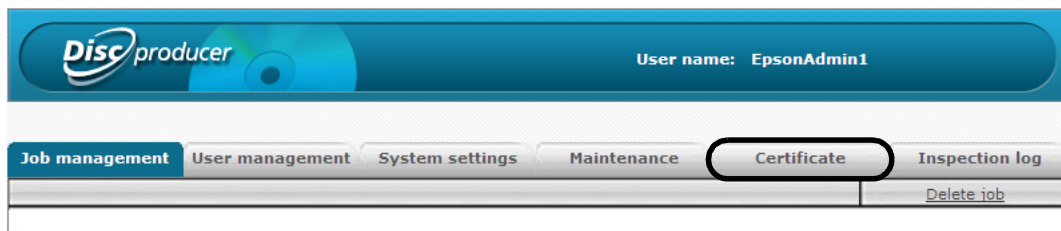

- 3 Click [Browse], specify the save location of the server certificate file, and click [Upload].

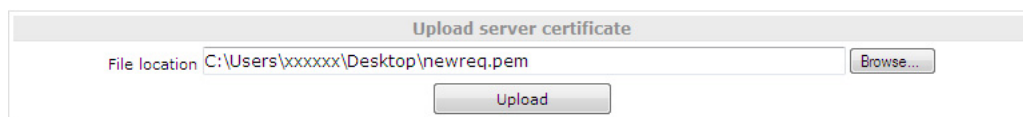

# Setting the language

After you set the Publish Mode (see page 31 in this guide), you can change the language setting for messages displayed on the LCD of this product from English to Spanish, French, Italian, Dutch, Portuguese, Japanese, or German.

Use the procedure below to change the language setting.

- 1 Press the MENU button.  
The top menu appears.
- 2 Use the ▲/▼ buttons to display the language settings (“Top menu Language”) screen, and press the ↵ button.

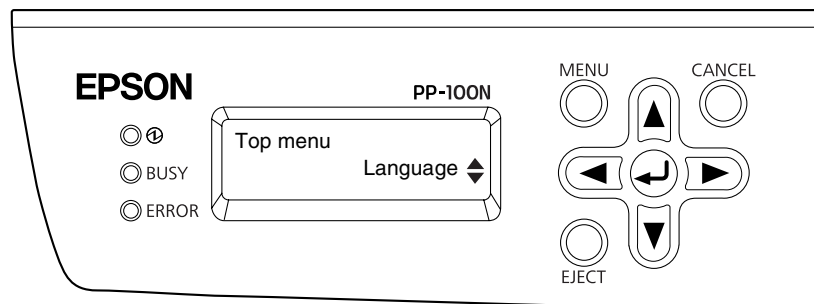

- 3 Use the ▲/▼ buttons to display the language that you want to change, and press the ↵ button.

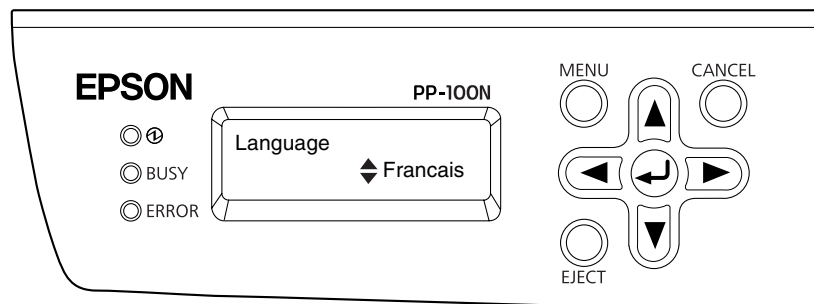

# Administration and Management

## Closing and opening the disc cover

The disc cover must always be opened and closed by the administrator when, for example, discs are loaded or replenished, or an error occurs.

### Unlocking the disc cover

If the security lock switch is set to on, the disc cover is locked automatically each time it is closed.

To unlock the disc cover, use the disc cover key or operate the control panel.



Be sure to set the security lock switch to on in the PIN Controlled Mode and Security Mode.

### Using the disc cover key to unlock the lock

Insert the disc cover key into the disc cover lock, and turn it to the [UNLOCK] position.

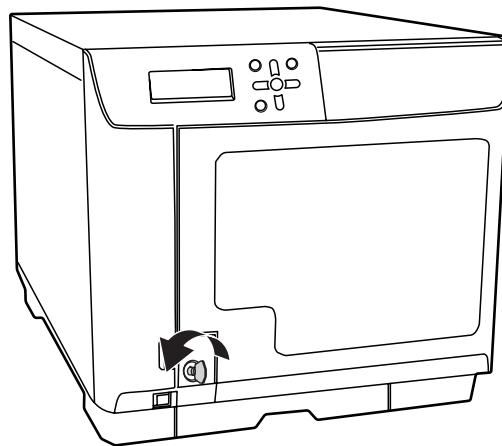

The disc cover key should be carefully managed by the administrator.

## Using the control panel to unlock the lock

- 1 Press the MENU button.  
The disc cover unlock screen appears.

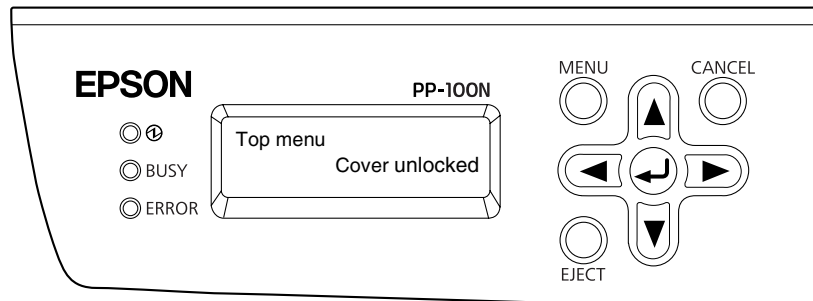

- 2 Press the  button.

- 3 Use the authentication keypad to enter the user number, and press the Enter key.

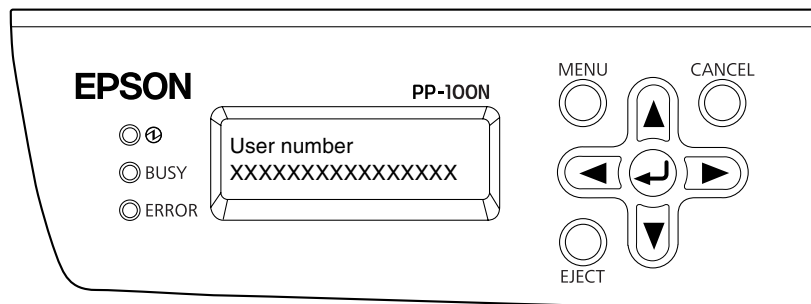

- 4 Use the authentication keypad to enter the PIN, and press the Enter key.

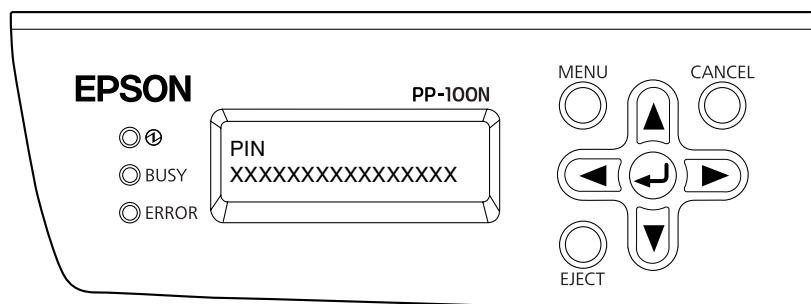

When the disc cover is unlocked, "Disc cover can be opened" appears on the LCD.

### Notes

If the disc cover is not opened within 5 seconds after the lock is unlocked, the disc cover is locked again.

## Opening the disc cover



- Do not open the disc cover while a job is being processed (BUSY LED is flashing). Doing so may affect the quality of writing or printing.
- If you open the disc cover while a job is being processed, an alarm tone sounds and the status of the current job becomes standby. If you close the disc cover, job processing resumes automatically.
- If a job is being processed, first pause the job and then open the disc cover. See "Pausing jobs" on page 73 in this guide for the procedure to pause a job.
- For safety reasons, never insert your hand while the arm is operating.
- Do not operate the stacker while the arm is operating. Doing so may damage the arm.

**1** If the disc cover is locked, unlock it.  
See "Unlocking the disc cover" on page 63 in this guide for the procedure to unlock the lock.

**2** Hold the handle, and open the disc cover in the direction indicated by the arrow in the figure below.

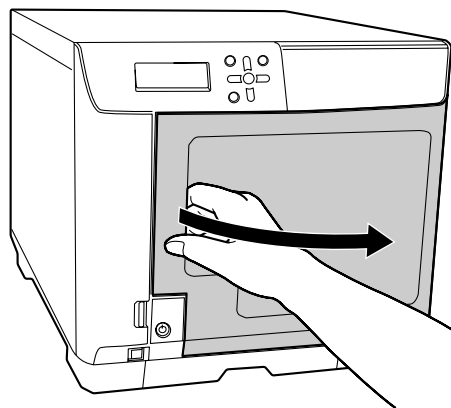

- Do not leave the disc cover open. If the disc cover is left open, a slow beeping alarm tone sounds. The alarm tone sounds every 10 seconds and then stops. After 60 seconds elapse, it changes to a fast beeping warning tone. The warning tone does not stop until the disc cover is locked.
- If notification email transmission is set, an email is sent to notify the administrator if the disc cover is left open for 60 seconds, or is closed for 10 seconds without being locked.

## Closing the disc cover

Hold the handle, and close the disc cover in the direction indicated by the arrow in the figure below.

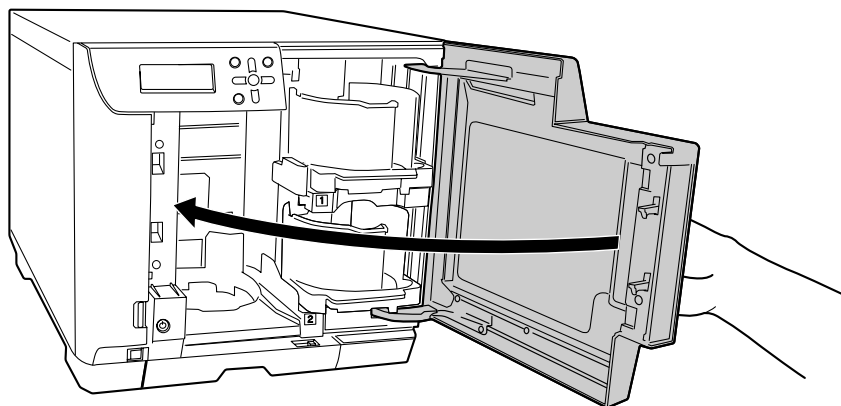

If you used the disc cover key to open the disc cover, be sure to turn the key to the (LOCK) position and remove it from the disc cover lock after you close the disc cover.

## Loading discs

This section describes how to load discs in the stacker, and insert the stacker.



- If the notification email transmission is set, an email is sent to notify the administrator when the input stacker runs out of discs.
- Load the discs in Stacker 1. Do not load discs in the drives or printer. Furthermore, do not load discs between drive 1 and drive 2. You may be unable to remove them.

### 1 Fan a stack of discs to prevent them from sticking together.



- Be sufficiently careful not to scratch a disc.
- If a long time elapses after discs are loaded, the fanned discs may stick together again. Fan the discs again if a long time has elapsed since they were loaded.

### 2 Open the disc cover, and take out Stacker 1.

### 3 Load discs into Stacker 1.

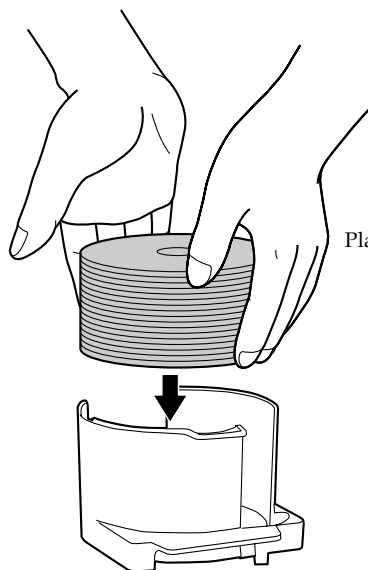

Place the label surface facing upwards.



- You can load up to approximately 50 discs. Do not load discs above the red line on the stacker. The product may malfunction, or the discs may be damaged.
- Make sure that the bottom of the stacker is not dirty before loading the discs.

### 4 Insert Stacker 1, and close the disc cover.

# Managing jobs

This section describes how to check, pause, resume, and cancel published jobs, and delete job data.

## Checking job information

You can check the history and detailed information of jobs on the [Job management] screen after logging in to EPSON Total Disc Net Administrator. See “Logging in to EPSON Total Disc Net Administrator” in the *PP-100N Security User’s Guide* for the login procedure.

	Date published	Job name	Status	Publisher
<a href="#">Details</a>	Dec 3, 2008	DVD_Video	Publishing	EpsonUser1
<a href="#">Details</a>	Dec 3, 2008	sample_data	Waiting to be ejected	EpsonUser1
<a href="#">Details</a>	Dec 2, 2008	Untitled	Completed	EpsonUser2
<a href="#">Details</a>	Dec 2, 2008	20090101	Completed	EpsonUser1

The job list displays all jobs with the following status that were published for this product.

- Registered (Security Mode only)
- Waiting for approval (Security Mode only)
- Waiting
- Publishing
- Waiting to be ejected
- Completed
- Paused
- Pausing
- Canceling
- Standby
- Recovering



The job status display is not updated automatically. To update the display, click (Refresh) on the (View) menu of Internet Explorer.

**Notes**

- If you use search options, a job list of the search results is displayed in accordance with the conditions specified.
- Click (Details) of the job you want to check to display more detailed job information.

## Canceling job applications (Security Mode only)

Use the following procedure to cancel a job application before it is approved in the approval workflow.



To cancel an application, the status of the job needs to be in Registered or Waiting for approval.

- 1 Log in to EPSON Total Disc Net Administrator.  
See “Logging in to EPSON Total Disk Not Administrator” in the *PP-100N Security User’s Guide* for the login procedure.
- 2 Search for the job for which you want to cancel the application.

The screenshot shows the 'Disc producer' interface with the user name 'EpsonAdmin1'. The 'Job management' tab is selected. Below the navigation tabs, there is a 'Job status list' section. A search form is highlighted with a red circle, containing the following fields:

Search target	Date	Status
Date published	December 2, 2008	Waiting for approval

A 'Search' button is located to the right of the search form.

- 3 Click [Details].

The screenshot shows the same interface as the previous one, but now a table of job applications is visible. The 'Details' button for the first job is highlighted with a red circle.

	Date published	Job name	Status	Publisher
<a href="#">Details</a>	Dec 2, 2008	20090101	Waiting for approval	EpsonUser1

1/1

4 Click [Cancel].

The screenshot shows the 'Disc producer' application interface. At the top, the user name is 'EpsonAdmin1'. The main menu includes 'Job management', 'User management', 'System settings', 'Maintenance', 'Certificate', and 'Inspection log'. The 'Job details' window is open, displaying the following information:

Disc information			Basic information	
Name	Size	Date Modified	Job name	20090101
image (1).bmp	7968	10/15/2008 15:15:34	Publisher	EpsonUser1
image (10).bmp	282306	10/15/2008 17:29:08	Date published	Dec 2, 2008 15:15:54
image (11).bmp	185901	10/15/2008 17:28:04	Last updated	Dec 2, 2008 15:16:08
image (12).bmp	13724	10/15/2008 15:14:02	Status	Waiting for approval
image (13).bmp	19983	10/15/2008 15:14:04		
image (14).bmp	12844	10/15/2008 15:14:04		
image (15).bmp	26354	10/15/2008 15:12:22		
image (18).bmp	539382	12/10/2008 17:12:06		

Disc type: Data CD  
Size: 0 to 650 700 MB (17.9 MB)

Approval workflow		Distribution information	
Date of application	Dec 2, 2008 15:16:08		
Approver	EpsonApprover1		
Proxy approver			
Reason for application			

Number of discs to be published: 3 Disc(s)  
Number of discs published: 0 Disc(s)

Job type: Publish  
Write verification: None  
Write speed: 40 X

A 'Cancel' button is located at the bottom right of the window.

5 Click [OK].

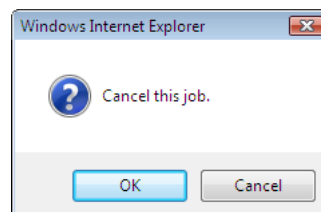

6 The job list appears in the [Job management] screen.  
The job disappears when the job application is canceled.

**Notes**

If notification email transmission is set, an email is sent to notify the administrator that the job is canceled.

## Checking the job processing status

Use the following procedure to check the job processing status.

- 1 Start EPSON Total Disc Monitor.  
See “Starting EPSON Total Disc Monitor” in the *PP-100N Security User’s Guide* for the start procedure.
- 2 Click the [Unfinished Job] tab or [Finished Job] tab.  
The [Unfinished Job] screen or [Finished Job] screen appears.

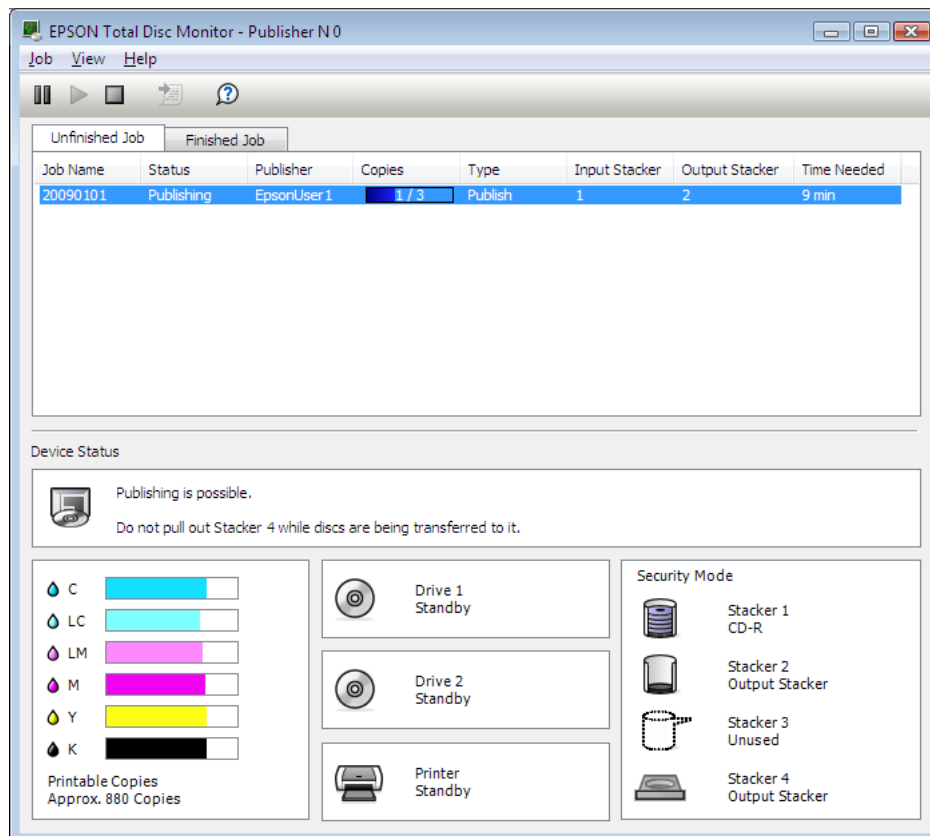

[Unfinished Job] screen: Displays a list of jobs for which the status is Waiting, Publishing, Paused, Pausing, Canceling, Standby, or Recovering.

[Finished Job] screen: Displays a list of jobs for which the status is Published and Cancel. When the published discs are taken out, the job display disappears.



In the Security Mode, jobs not approved in the approval workflow are not displayed.

## Pausing jobs

When a job is being processed, be sure to pause job processing before you perform a disc cover operation or other operation of the product unit.

Use the following procedure to pause a job.



Only a job for which the status is Waiting, Publishing, Standby, or Recovering can be paused.

- 1 Start EPSON Total Disc Monitor.  
See "Starting EPSON Total Disc Monitor" in the *PP-100N Security User's Guide* for the start procedure.
- 2 Select the job for which you want to pause processing, and click  [Pause].

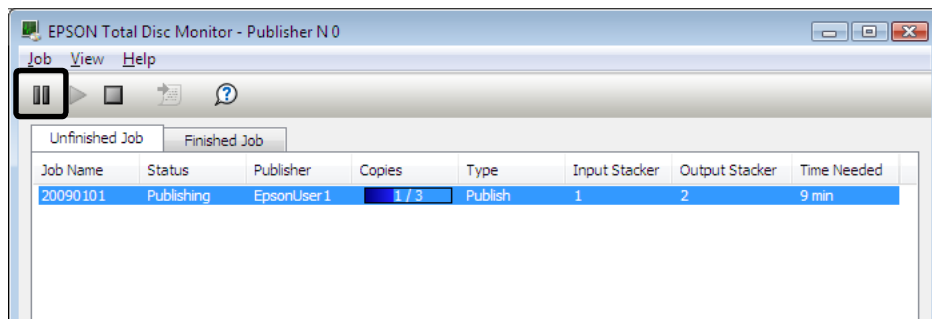

- 3 Enter your user name and password, and click [OK].

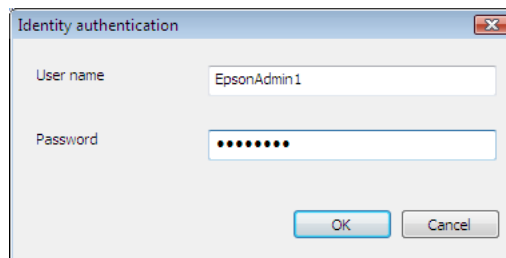

When the job is paused, the job status display changes from Pausing to Paused.



- If there is a disc being published, the job is paused after the processing is finished.
- The processing of any subsequent job also does not start while the job is paused.

### Notes

Selecting a paused job and clicking  (Cancel) allows you to cancel the job without resuming processing.

## Resuming jobs

Use the following procedure to resume processing of a paused job.



Only a job for which the status is Paused or Pausing can be resumed.

- 1 Start EPSON Total Disc Monitor.  
See “Starting EPSON Total Disc Monitor” in the *PP-100N Security User’s Guide* for the start procedure.
- 2 Select the job for which you want to resume processing, and click  [Resume].

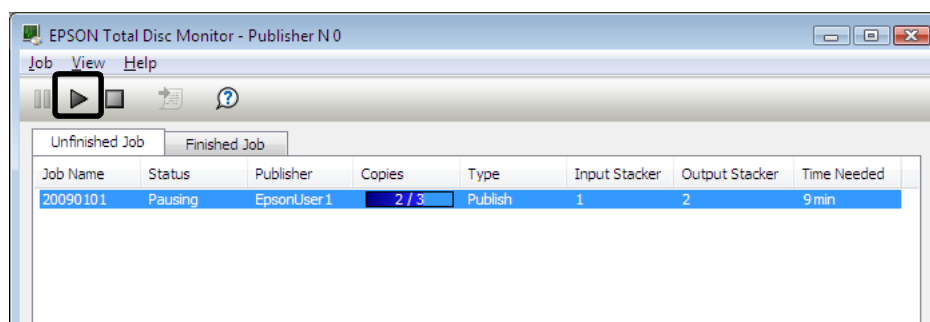

- 3 Enter your user name and password, and click [OK].

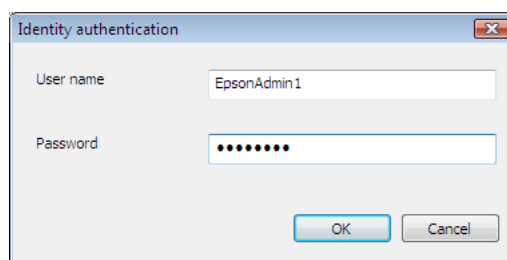

When the job is resumed, the job status display changes from Paused to Publishing or Waiting.

## Canceling jobs

Use the following procedure to cancel processing of a job.



Only a job for which the status Waiting, Publishing, Paused, Pausing, Standby, or Recovering can be canceled.

- 1 Start EPSON Total Disc Monitor.  
See "Starting EPSON Total Disc Monitor" in the *PP-100N Security User's Guide* for the start procedure.
- 2 Select the job you want to cancel, and click  [Cancel].

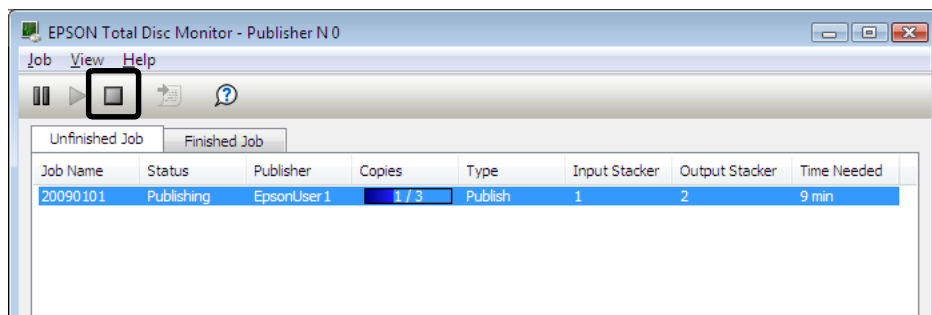

- 3 Click [Yes].

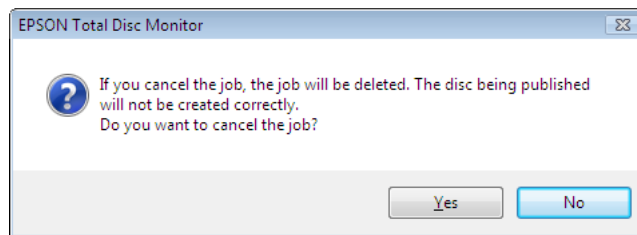

- 4 Enter your user name and password, and click [OK].

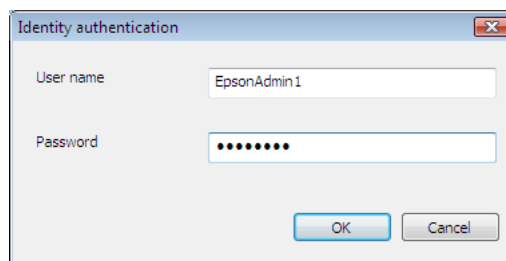

When the job is canceled, the job appears in the [Finished Job] screen of EPSON Total Disc Monitor.



If a disc is being published, that processing is stopped, and the disc is output to Stacker 2.

### Notes

If notification email transmission is set, an email is sent to notify the publisher that the job is finished.

## Deleting jobs

Use the following procedure to delete spool data and job history when, for example, there is little free space remaining on the product's hard disk.

- 1 Log in to EPSON Total Disc Net Administrator.  
See "Logging in to EPSON Total Disc Net Administrator" in the *PP-100N Security User's Guide* for the login procedure.
- 2 Click [Delete job].

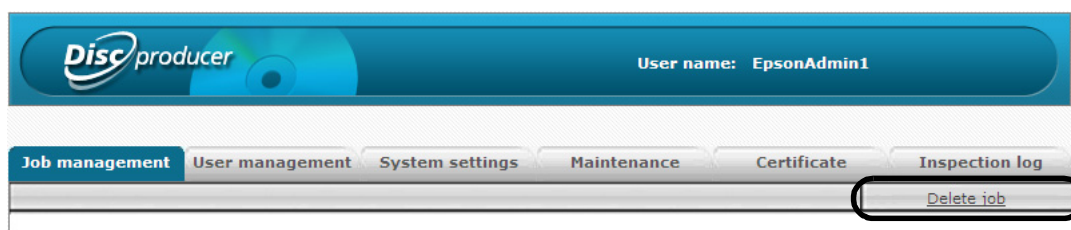

- 3 Use the search options to find the job you want to delete.

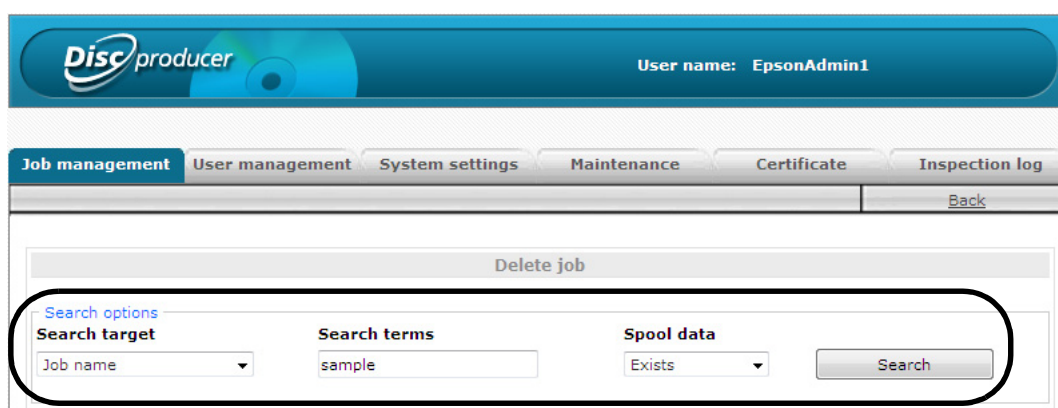

- 4 Select the check box for the job you want to delete, and click [Delete spool data] or [Delete spool data and job history].

The screenshot shows the 'Delete job' page in the Disc producer interface. At the top, the user is logged in as 'EpsonAdmin1'. The navigation menu includes 'Job management', 'User management', 'System settings', 'Maintenance', 'Certificate', and 'Inspection log'. A 'Back' button is located in the top right corner of the main content area.

The 'Delete job' section contains a search form with the following fields:

- Search target:** Job name (dropdown)
- Search terms:** sample (text input)
- Spool data:** Exists (dropdown)
- Search:** (button)

Below the search form are 'Select all' and 'Deselect all' buttons, with a note: '[Select all] and [Deselect all] are only valid for this page.'

The main content is a table with the following data:

	Date published	Job name	Publisher	Spool data
<input checked="" type="checkbox"/>	Dec 3, 2008	sample_data	EpsonUser1	19 MB

Below the table, the page number '1/1' is displayed. At the bottom of the page, there are two buttons: 'Delete spool data' and 'Delete spool data and job history'.

- 5 Click [OK] in the deletion confirmation message that appears.

# Managing users

## Checking user information

Use the following procedure to check registered user information.

- 1 Log in to EPSON Total Disc Net Administrator.  
See “Logging in to EPSON Total Disc Net Administrator” in the *PP-100N Security User’s Guide* for the login procedure.
- 2 Click the [User management] tab.

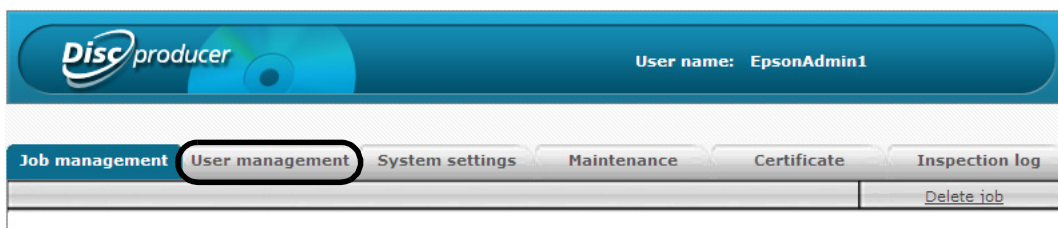

The [User management] screen appears.

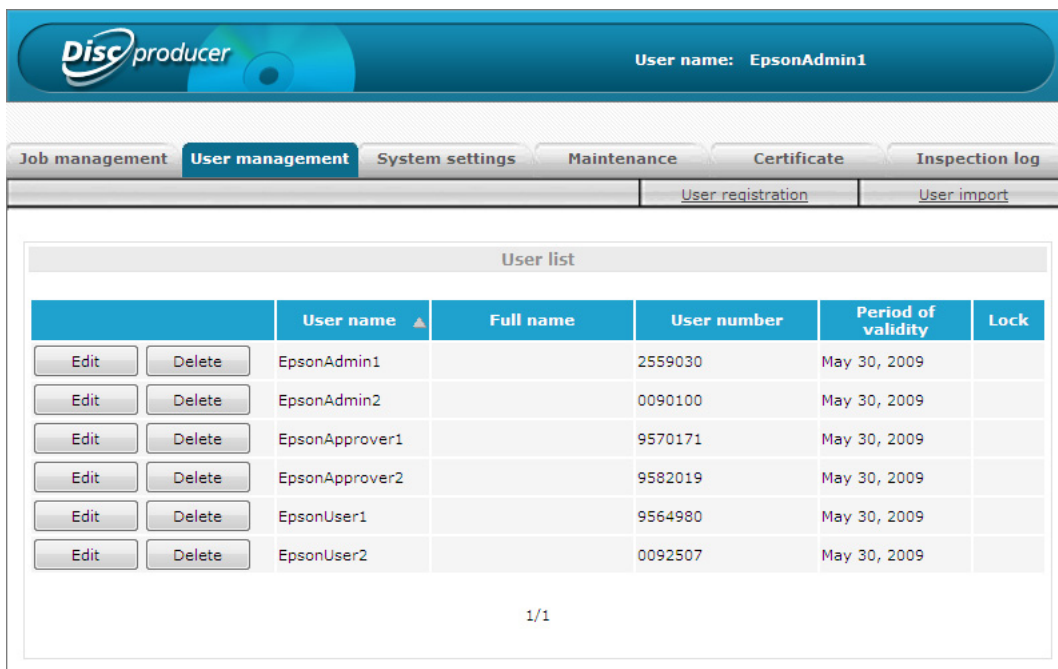

The user list displays the user name, full name, user number, period of validity for the password and PIN, and account lock status of a registered user.

### Notes

- Clicking (Edit) allows you to change the full name, mail address, and authority of a registered user.
- Clicking (Delete) allows you to delete the registered user information.
- If the user account is locked, (Unlock) is displayed for (Lock). Click (Unlock) to unlock the lock.

## Registering users

Use the following procedure to register a second or subsequent administrator, approver (Security Mode only), or publisher.

### Notes

You can perform a batch registration of multiple users. See "Batch registering users" on page 82 in this guide for the procedure to perform a batch registration of multiple users.

- 1 Log in to EPSON Total Disc Net Administrator.  
See "Logging in to EPSON Total Disc Net Administrator" in the *PP-100N Security User's Guide* for the login procedure.
- 2 Click the [User management] tab.

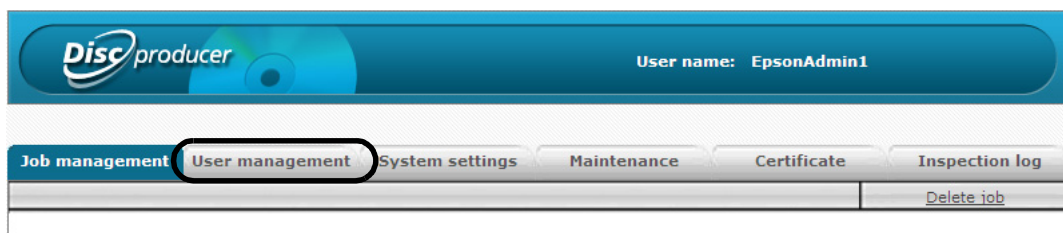

- 3 Click [User registration].

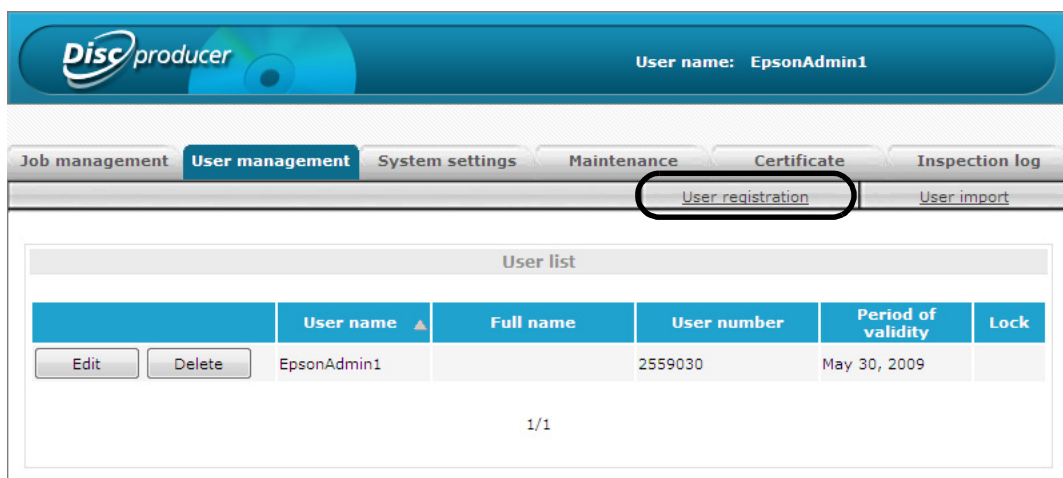

#### 4 Enter the information for each item, and click [Save].

The screenshot shows the 'User registration' form in the Epson Disc producer interface. The form includes the following fields and values:

Field	Value
User name*	EpsonApprover1
Password*	.....
Confirm password*	.....
Full name	
Email address	
Authority	<input checked="" type="checkbox"/> Approver <input type="checkbox"/> Administrator
User number*	9570171
PIN*	.....
PIN confirmation*	.....

\*are required fields.

Save

- User name: Enter the user name to use for identity authentication in EPSON Total Disc Maker/EPSON Total Disc Monitor/EPSON Total Disc Net Administrator.
- Password: Enter the password to use for identity authentication in EPSON Total Disc Maker/EPSON Total Disc Monitor/EPSON Total Disc Net Administrator.
- Confirm password: Enter the password again for confirmation.
- User number: Enter the user number to use for performing identity authentication with the authentication keypad.
- PIN: Enter the PIN to use for performing identity authentication with the authentication keypad.
- PIN confirmation: Enter the PIN again for confirmation.



- Be sufficiently careful not to set the wrong authority.
  - \* To add an administrator, select the (Administrator) check box.
  - \* To add an approver (Security Mode only), select the (Approver) check box.
- Enter 5 to 16 alphanumeric characters for the user name.
- Enter 5 to 16 alphanumeric characters or symbols (".", "-", "\_") for the password.
- The password is case-sensitive.
- Do not set a date of birth, employee number, or anything else that is easy to guess for the password or PIN.
- Enter 5 to 16 numbers for the user number and PIN.
- Manage the password and PIN so that they cannot be used by anyone other than the user.
- The period of validity for the password and PIN is 180 days. Change them regularly before the period of validity ends. (See "Changing password and PIN" on page 89 in this guide for the procedure to change the password and PIN.)
- You can register the information for up to 100 users.

**Notes**

Enter a full name and email address if necessary. An email address needs to be entered if notification email transmission is set. See "Notification email transmission settings" on page 50 in this guide for details on setting the notification email transmission.

**5** Click [OK] in the confirmation message that appears.

The user list of the [User management] screen appears.

Check that the user is registered correctly.

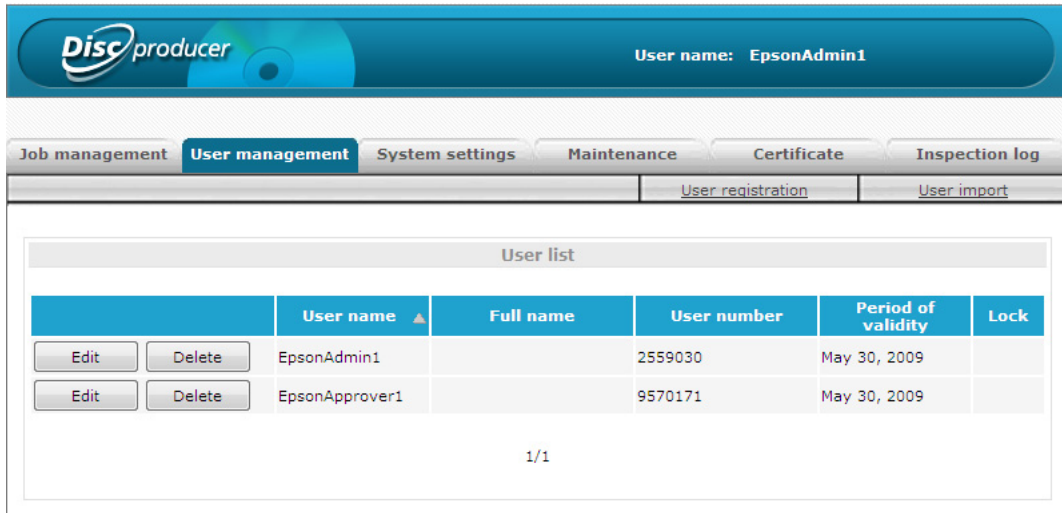

The screenshot shows the 'Disc producer' interface with the 'User management' tab selected. The 'User list' table contains the following data:

		User name ▲	Full name	User number	Period of validity	Lock
Edit	Delete	EpsonAdmin1		2559030	May 30, 2009	
Edit	Delete	EpsonApprover1		9570171	May 30, 2009	

1/1



Inform the user of the set user name and password. The user changes the password and PIN after logging in.

**Notes**

- Clicking (Edit) allows you to change the full name, mail address, and authority of a registered user.
- Clicking (Delete) allows you to delete the registered user information.

## Batch registering users

Use the following procedure to perform a batch registration of multiple users.



- It is not possible to assign approver (Security Mode only) or administrator authority when performing a batch registration of multiple users. To set authority, change the information of each user after performing a batch registration. (See “Changing user information” on page 85 in this guide.)
- You can register up to 100 users including the number of users for which user information is already registered.

### 1 Create a CSV format file containing the information of the following items.

- (1) User name: The user name to use for identity authentication in EPSON Total Disc Maker/EPSON Total Disc Monitor/EPSON Total Disc Net Administrator.
- (2) Password: The password to use for identity authentication in EPSON Total Disc Maker/EPSON Total Disc Monitor/EPSON Total Disc Net Administrator.
- (3) User number: The user number to use for identity authentication with the authentication keypad.
- (4) PIN: Enter the PIN to use for identity authentication with the authentication keypad.

The screens shown here are from Windows XP.

	(1)	(2)	Full name	Mail address	(3)	(4)
	A	B	C	D	E	F
1	EpsonUser2	user2epson			10000002	47259664
2	EpsonUser3	user3epson			10000003	55684721
3	EpsonUser4	user4epson			10000004	23654852
4	EpsonUser5	user5epson			10000005	47254639
5	EpsonUser6	user6epson			10000006	98254638
6	EpsonUser7	user7epson			10000007	35489511
7	EpsonUser8	user8epson			10000008	65698423
8	EpsonUser9	user9epson			10000009	25486977
9	EpsonUser10	user10epson			10000010	58999652
10	EpsonUser11	user11epson			10000011	18569335
11	EpsonUser12	user12epson			10000012	25789314



- Enter 5 to 16 alphanumeric characters for the user name.
- Enter 5 to 16 alphanumeric characters or symbols (“.”, “-”, “\_”) for the password.
- The password is case-sensitive.
- Do not set a date of birth, employee number, or anything else that is easy to guess for the password or PIN.
- Enter 5 to 16 numbers for the user number and PIN.
- Manage the passwords and PINs so that they cannot be used by anyone other than the users.
- The period of validity for the password and PIN is 180 days. Change them regularly before the period of validity ends. (See “Changing password and PIN” on page 89 in this guide for the procedure to change the password and PIN.)

**Notes**

Enter a full name and email address if necessary. An email address needs to be entered if notification email transmission is set. See “Notification email transmission settings” on page 50 in this guide for details on the notification email transmission settings.

- 2 Log in to EPSON Total Disc Net Administrator.  
See “Logging in to EPSON Total Disc Net Administrator” in the *PP-100N Security User’s Guide* for the login procedure.
- 3 Click [User management] tab.

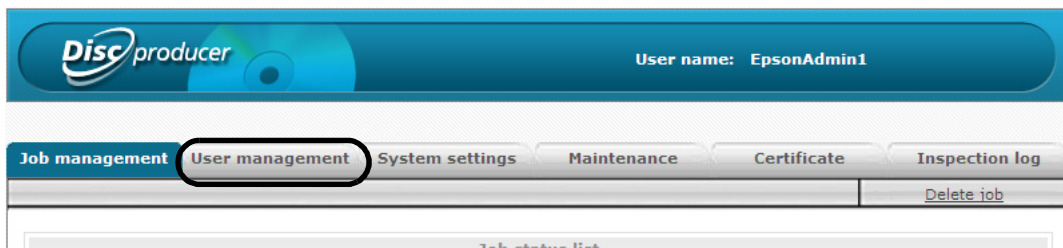

- 4 Click [User import].

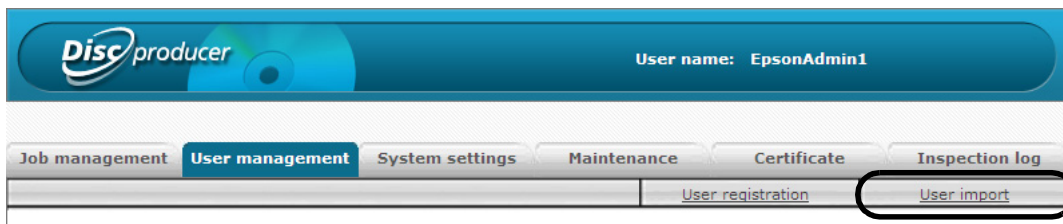

- 5 Click [Browse], specify the CSV file, and click [Import].

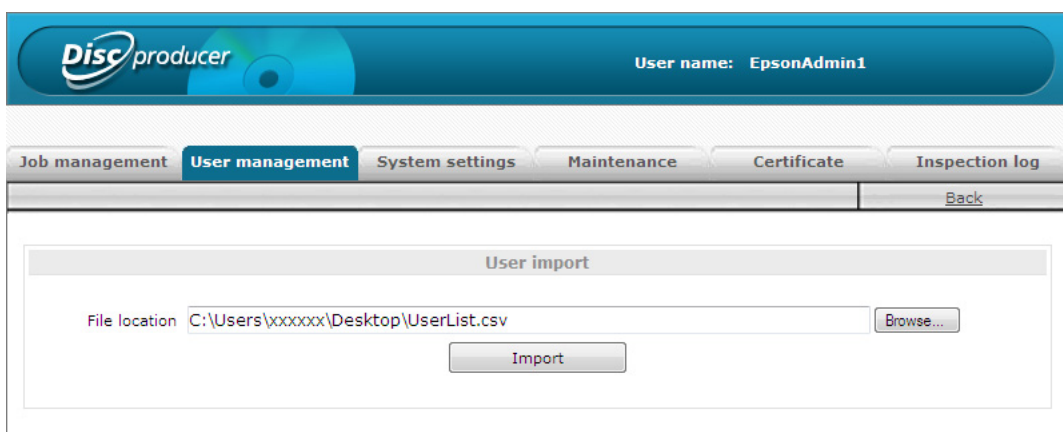

## 6 Click [OK].

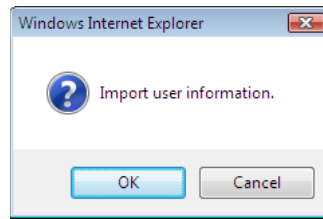

When the registration is finished, the user list of the [User management] screen appears. If the registration of even one user fails, the line number of each user that could not be registered and the corresponding cause is displayed. The users of other line numbers are registered.



- The administrator should carefully manage CSV files containing passwords and PINs.
- Inform each user of the set user name and password. The user changes the password and PIN after logging in.

## Changing user information

Use the following procedure to change registered user information.

- 1 Log in to EPSON Total Disc Net Administrator.  
See “Logging in to EPSON Total Disc Net Administrator” in the *PP-100N Security User’s Guide* for the login procedure.
- 2 Click the [User management] tab.

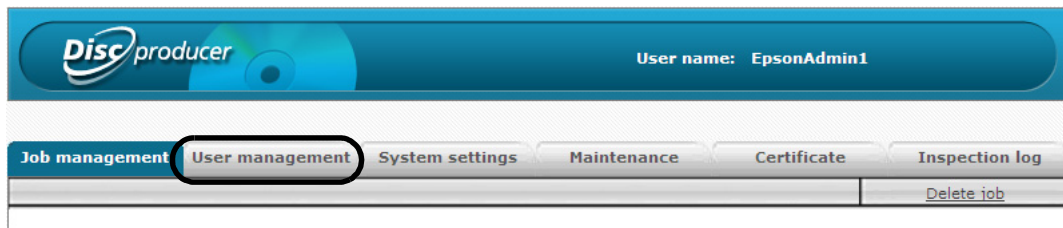

- 3 Click [Edit] of the user for which you want to change the information.

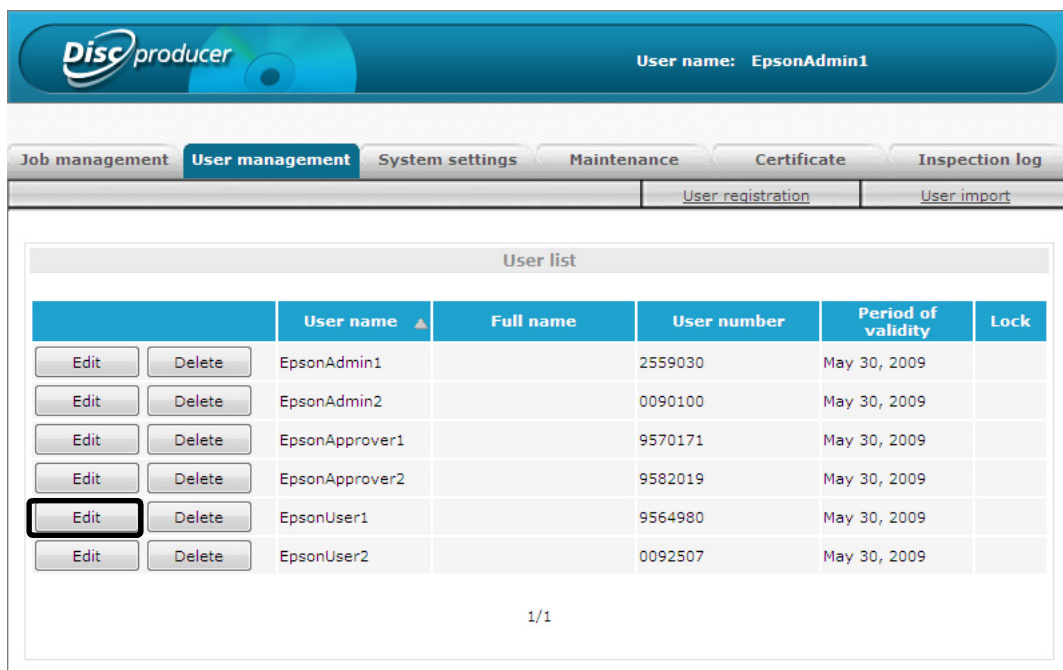

4 Change the full name, mail address, and authority of the user as necessary, and click [Save].



Be sufficiently careful not to set the wrong authority.

- To assign administrator authority, select the (Administrator) check box.
- To assign approver authority (Security Mode only), select the (Approver) check box.

Disc producer User name: EpsonAdmin1

Job management **User management** System settings Maintenance Certificate Inspection log

Change password Back

Edit user

User name	EpsonUser1
Full name	
Email address	xxxxx@xxx.xx.xx
Authority	<input type="checkbox"/> Approver <input type="checkbox"/> Administrator

Save

5 Click [OK] in the update confirmation message that appears.

## Deleting user information

Use the following procedure to delete registered user information.

- 1 Log in to EPSON Total Disc Net Administrator.  
See “Logging in to EPSON Total Disc Net Administrator” in the *PP-100N Security User’s Guide* for the login procedure.
- 2 Click the [User management] tab.

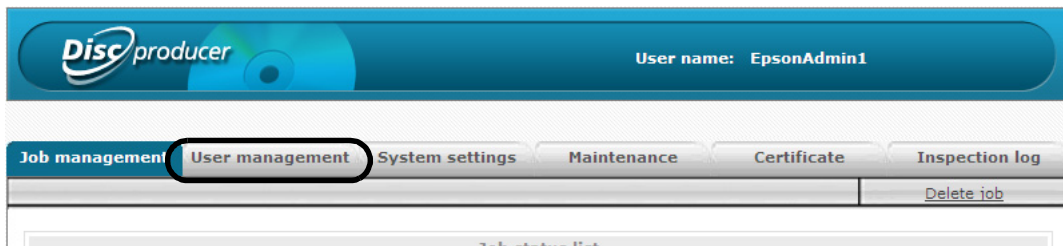

- 3 Click [Delete] for the user for which you want to delete the information.

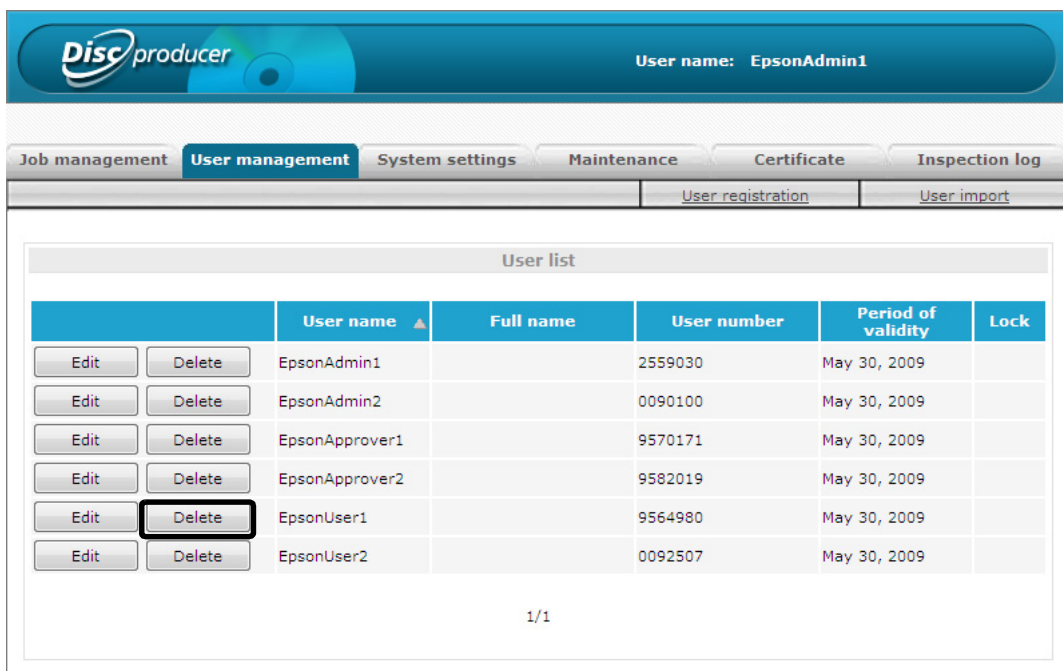

4 Click [OK].

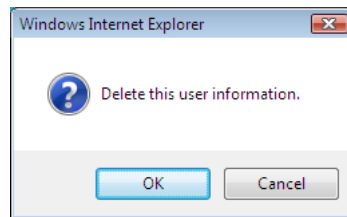

The user list of the [User management] screen appears.  
Check that the user was deleted.

## Changing password and PIN

Use the following procedure to change the password and PIN of a registered user.



- The period of validity for the password and PIN is 180 days. Change them regularly before the period of validity ends.
- When there are only 30 days left until the period of validity for the password and PIN expires, a message appears to notify you that the period is to expire soon each time you log in to EPSON Total Disc Net Administrator.
- If notification email transmission is set, when there are only 30 days left until the period of validity for the password and PIN expires, an email is sent to notify the user that the period of validity is to expire soon.
- Manage the password and PIN so that they cannot be used by anyone other than the user.

### 1 Log in to EPSON Total Disc Net Administrator.

See “Logging in to EPSON Total Disc Net Administrator” in the *PP-100N Security User’s Guide* for the login procedure.

### 2 Click the [User management] tab.

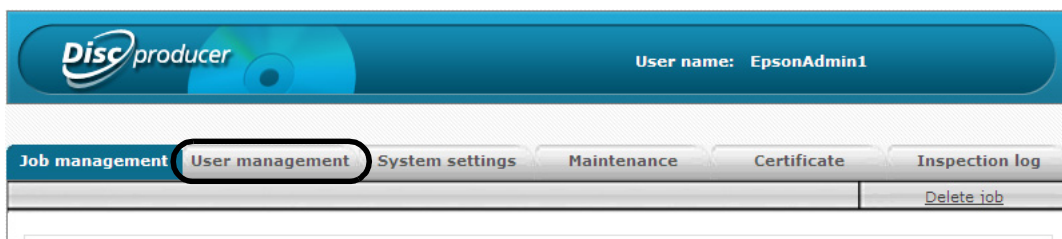

### 3 Click [Edit] for the user for which you want to change the password and PIN.

User list						
		User name ▲	Full name	User number	Period of validity	Lock
Edit	Delete	EpsonAdmin1		2559030	May 30, 2009	
Edit	Delete	EpsonAdmin2		0090100	May 30, 2009	
Edit	Delete	EpsonApprover1		9570171	May 30, 2009	
Edit	Delete	EpsonApprover2		9582019	May 30, 2009	
Edit	Delete	EpsonUser1		9564980	May 30, 2009	
Edit	Delete	EpsonUser2		0092507	May 30, 2009	

1/1

4 Click [Change password].

The screenshot shows the 'Disc producer' web interface. At the top right, the user is logged in as 'EpsonAdmin1'. The navigation bar includes 'Job management', 'User management', 'System settings', 'Maintenance', 'Certificate', and 'Inspection log'. A 'Change password' link is circled in the navigation bar. Below the navigation bar is the 'Edit user' form with the following fields:

Edit user	
User name	EpsonUser1
Full name	<input type="text"/>
Email address	xxxxx@xxx.xx.xx
Authority	<input type="checkbox"/> Approver <input type="checkbox"/> Administrator

A 'Save' button is located at the bottom right of the form.

5 Enter the new password and PIN, and click [Save].

The screenshot shows the 'Disc producer' web interface. At the top right, the user is logged in as 'EpsonAdmin1'. The navigation bar includes 'Job management', 'User management', 'System settings', 'Maintenance', 'Certificate', and 'Inspection log'. A 'Back' link is visible in the navigation bar. Below the navigation bar is the 'Change password' form with the following fields:

Change password	
User name	EpsonUser1
Full name	<input type="text"/>
Password	<input type="password"/>
Confirm password	<input type="password"/>
User number	9564980
PIN	<input type="password"/>
PIN confirmation	<input type="password"/>

A 'Save' button is located at the bottom right of the form.



- Enter 5 to 16 alphanumeric characters and symbols (".", "-", "\_") for the password.
- The password is case-sensitive.
- Enter from 5 to 16 numbers for the PIN.
- Do not set a date of birth, employee number, or anything else that is easy to guess for the password or PIN.

6 Click [OK].

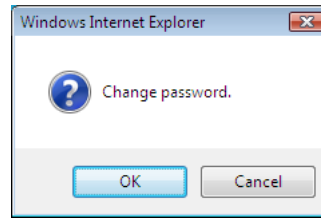

## Unlocking the user account

If you enter the wrong password three times in a row when publishing a job with EPSON Total Disc Maker, logging in to EPSON Total Disc Net Administrator, or performing a job operation (pausing, resuming, or canceling a job) using EPSON Total Disc Monitor, or you enter the wrong PIN three times in a row when operating the control panel (unlocking the disc cover, removing discs, configuring network settings, or restoring the product to the initial state), the user account is locked and the password or PIN can no longer be used. If this happens, use the following procedure to unlock the lock.

### Notes

- If notification email transmission is set, an email is sent to notify the administrator that the user account is locked.
- In the case of an administrator account, the lock is unlocked automatically when six hours elapse after the account was locked.
- In the case of a user account, the lock is unlocked automatically when one hour elapses after the account was locked.

- 1 Log in to EPSON Total Disc Net Administrator.  
See “Logging in to EPSON Total Disc Net Administrator” in the *PP-100N Security User’s Guide* for the login procedure.
- 2 Click the [User management] tab.

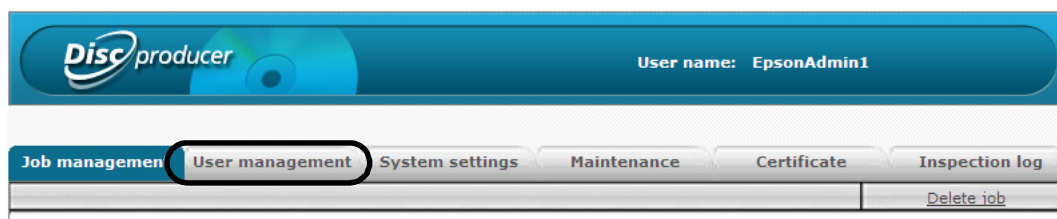

- 3 Click [Unlock] for the user for which you want to unlock the account.  
[Unlock] is displayed for [Lock] for a user whose account is locked.

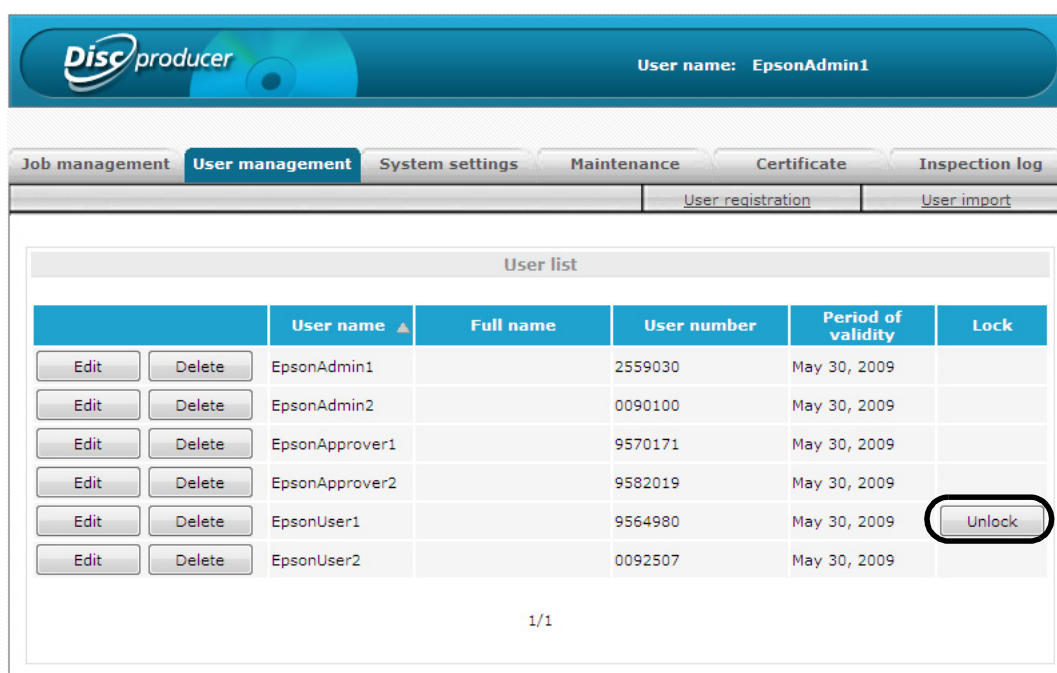

4 Click [OK].

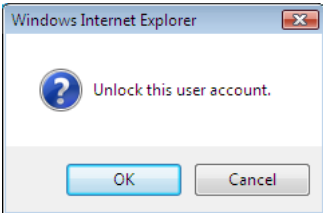

The user list of the [User management] screen appears.  
Check that the account is unlocked.

The screenshot shows the 'User management' interface. At the top, there is a blue header with the 'Disc producer' logo and the text 'User name: EpsonAdmin1'. Below the header is a navigation bar with tabs: 'Job management', 'User management' (selected), 'System settings', 'Maintenance', 'Certificate', and 'Inspection log'. Underneath the navigation bar are two sub-tabs: 'User registration' and 'User import'. The main content area is titled 'User list' and contains a table with the following data:

		User name ▲	Full name	User number	Period of validity	Lock
Edit	Delete	EpsonAdmin1		2559030	May 30, 2009	
Edit	Delete	EpsonAdmin2		0090100	May 30, 2009	
Edit	Delete	EpsonApprover1		9570171	May 30, 2009	
Edit	Delete	EpsonApprover2		9582019	May 30, 2009	
Edit	Delete	EpsonUser1		9564980	May 30, 2009	
Edit	Delete	EpsonUser2		0092507	May 30, 2009	

Below the table, the text '1/1' is displayed.

# Managing inspection logs

This product records events related to security as inspection logs. When a breach of security or other trouble may occur, inspection logs are useful for confirming whether or not there was a breach of security, and analyzing the security breach.



Only events that occur while the power of the product is on are recorded to inspection logs.

## Checking inspection logs

You can check inspection logs for up to the last 180 days.

Use the following procedure to check inspection logs.

- 1 Log in to EPSON Total Disc Net Administrator.  
See “Logging in to EPSON Total Disc Net Administrator” in the *PP-100N Security User’s Guide* for the login procedure.
- 2 Click the [Inspection log] tab.

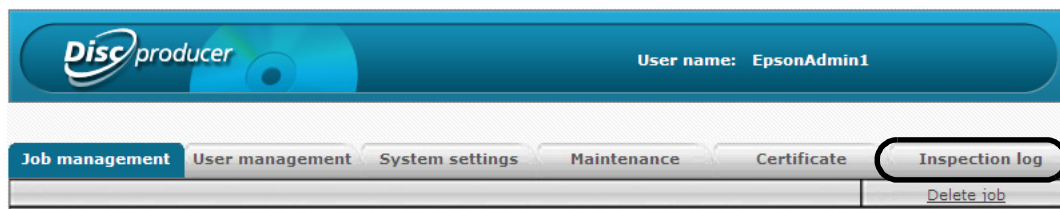

- 3 Select the date for which you want to check inspection logs, and click [Search].

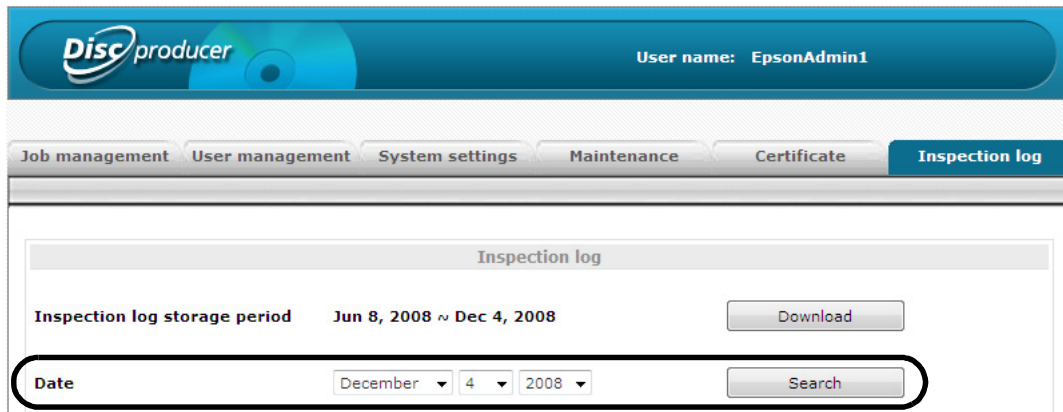

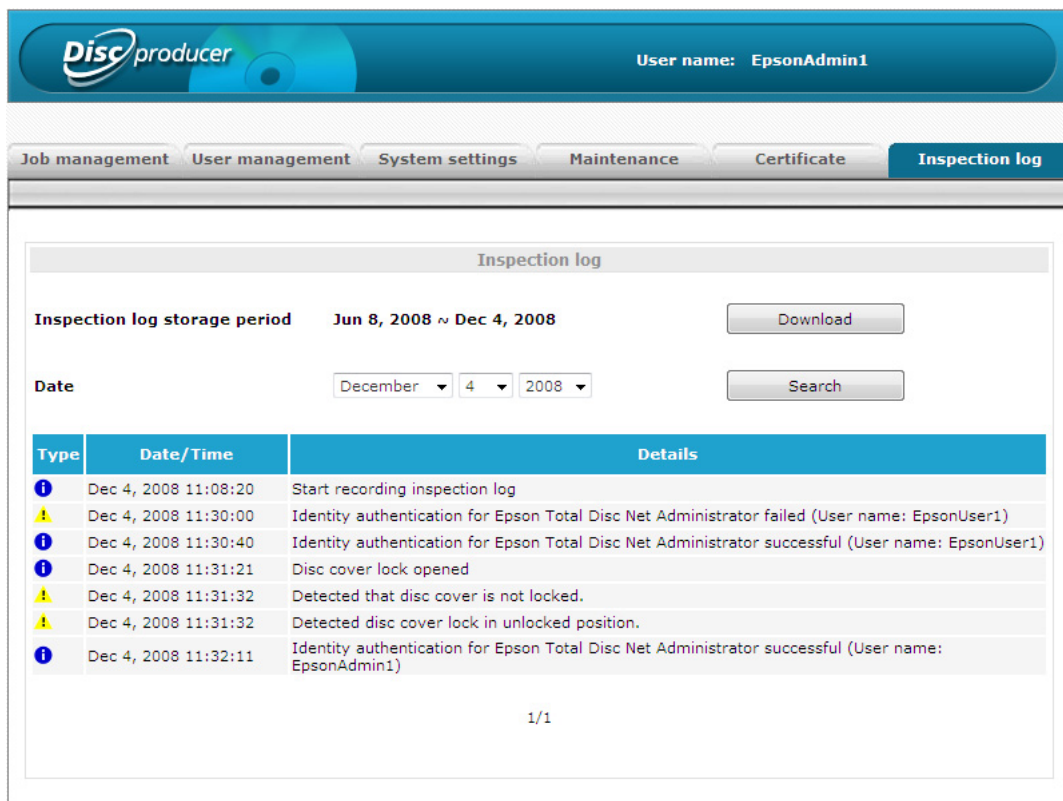

All of the inspection logs for the selected day are displayed together with the occurrence time and details.



#### Notes

The following icons are used to indicate the type of inspection log.

-  : An inspection log of notification level.
-  : An inspection log of warning level.

## Downloading inspection logs

You can download an inspection log file for the last 180 days.

Use the following procedure to download the inspection log file.

- 1 Log in to EPSON Total Disc Net Administrator.  
See “Logging in to EPSON Total Disc Net Administrator” in the *PP-100N Security User’s Guide* for the login procedure.
- 2 Click the [Inspection log] tab.

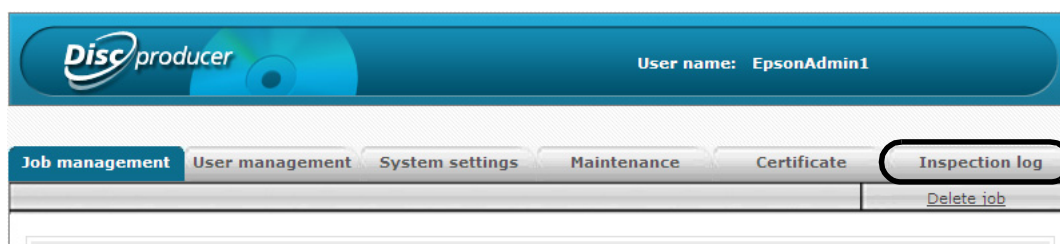

- 3 Click [Download].



- 4 Specify the save location for the inspection log file, and then save the inspection log file.

### Notes

The inspection log file is downloaded in self-extracting ZIP format. After extraction, you can check it in a text editor such as Microsoft Windows Notepad.

## Changing the Publish Mode

Publish Mode changes roughly fall into the following four types.

### Mode change I

Standard Mode/External Output Mode/Batch Mode $\leftrightarrow$ Standard Mode/External Output Mode/Batch Mode

### Mode change II

Standard Mode/External Output Mode/Batch Mode $\rightarrow$ PIN Controlled Mode/Security Mode

### Mode change III

PIN Controlled Mode/Security Mode $\rightarrow$ Standard Mode/External Output Mode/Batch Mode

### Mode change IV

PIN Controlled Mode $\leftrightarrow$ Security Mode



This section describes the change procedure for Mode change II, III, and IV.

**Notes** See Changing the Publish Mode in the *PP-100N Administrator's Guide* for Mode change I.

## Mode change II

Use the following procedure to change from Standard Mode/External Output Mode/Batch Mode to PIN Controlled Mode/Security Mode.

- 1** Restore the product to the initial state.  
See “Restoring to initial state” on page 107 in this guide for the procedure to restore the product to the initial state.
- 2** Press the power button to turn off the power.
- 3** Connect the authentication keypad.  
See “Connecting the authentication keypad” on page 21 in this guide for the procedure to connect the authentication keypad.
- 4** Set the security lock switch to ON.
- 5** Remove Stacker 3 if it is inserted.
- 6** Set the lock lever to the [UNLOCK] position.
- 7** Close the disc cover, and check that the disc cover is locked.
- 8** Press the power button to turn on the power.
- 9** When the mode selection screen appears on the LCD, press the EJECT button three times, and then press the MENU button.
- 10** In the mode selection screen displayed on the LCD, use ▲/▼ to display the Publish Mode to use, and press the ◀ button.

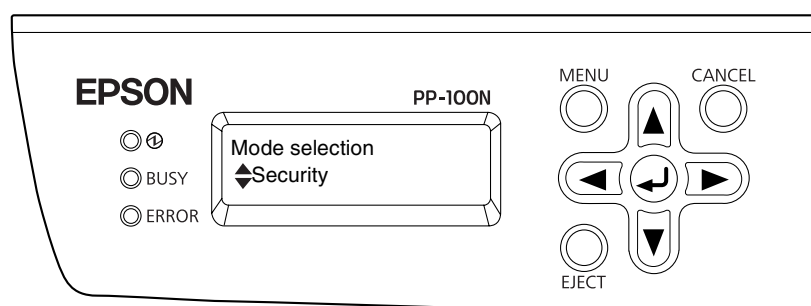

**11** When the confirmation message appears, press the  button.

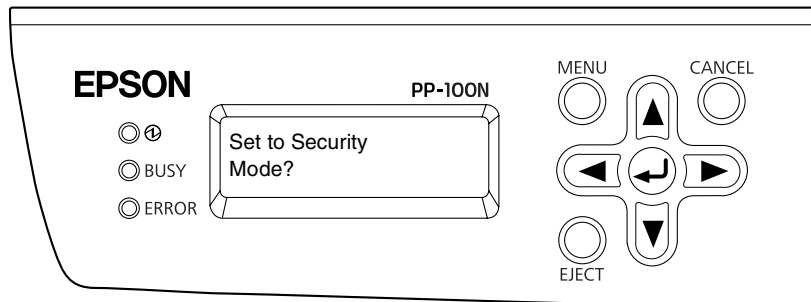

The initialization operation begins. Initialization takes 2 to 3 minutes.



- Never turn the power off during initialization.
- The operation of this product differs depending on the Publish Mode setting. To prevent the occurrence of an unexpected warning or error, check that the correct Publish Mode has been set after you change the Publish Mode.
- If the Security Mode is set, be sure to check the TOE version after changing the Publish Mode. See "Checking the TOE version (Security Mode only)" on page 114 in this guide for details on the TOE version check procedure.

When initialization is finished, [Please register an administrator] appears on the LCD. Perform the following operations and configure the settings that are required to use the product.

- Use the control panel to configure the network settings (see page 36 in this guide)
- Register the administrator (see page 42 in this guide)
- Configure the system settings (see page 47 in this guide)
- Install digital certificates (see page 56 in this guide)

#### **Notes**

After you change the Publish Mode, you can change the language setting for messages displayed on the LCD of this product from English to Spanish, French, Italian, Dutch, Portuguese, Japanese, or German. See "Setting the language" on page 62 in this guide if you want to change the language setting.

## Mode change III

Use the following procedure to change from PIN Controlled Mode/Security Mode to Standard Mode/External Output Mode/Batch Mode.

- 1** Restore the product to the initial state.  
See “Restoring to initial state” on page 107 in this guide for the procedure to restore the product to the initial state.
- 2** Press the power button to turn off the power.
- 3** Remove the authentication keypad.  
See “Connecting the authentication keypad” on page 21 in this guide for the removal procedure.
- 4** Set the security lock switch.  
See “Setting the security lock switch” in the *PP-100N Administrator’s Guide* for the procedure to set the security lock switch.
- 5** Insert a stacker in accordance with the Publish Mode.  
See “Installing the stackers” in the *PP-100N Administrator’s Guide*.
- 6** Press the power button to turn on the power.
- 7** In the mode selection screen displayed on the LCD, use ▲/▼ to display the Publish Mode to use, and press the ◀ button.

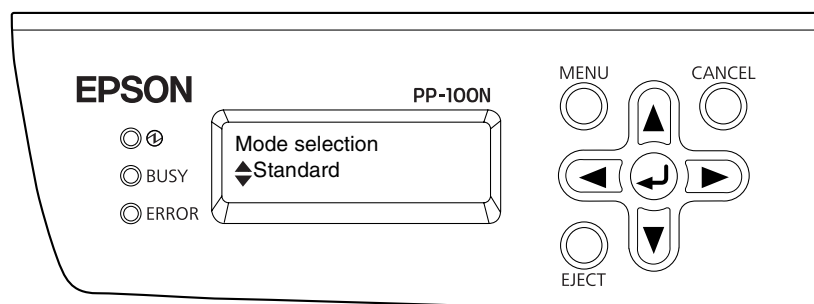

- 8** When the confirmation message appears, press the ◀ button.

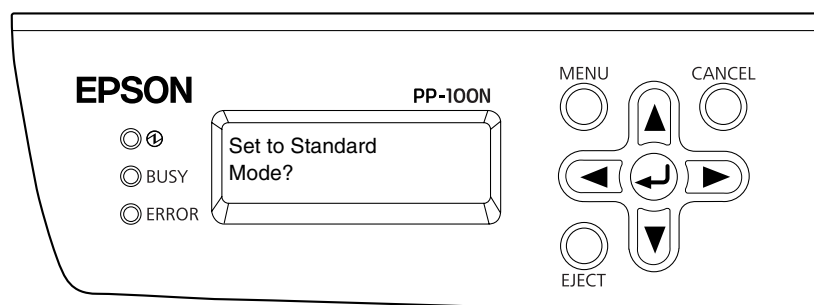

The initialization operation begins. Initialization takes two to three minutes.



- Never turn the power off during initialization.
- The operation of this product differs depending on the Publish Mode setting. To prevent the occurrence of an unexpected warning or error, check that the correct Publish Mode has been set after you change the Publish Mode.

When initialization is finished, [Please register an administrator] appears on the LCD. Perform the following work and configure the settings that are required to use the product.

- Use the control panel to configure the network settings (see “Use the control panel to configure the network settings” in the *PP-100N Administrator’s Guide*)
- Registering an administrator (see “Registering an administrator” in the *PP-100N Administrator’s Guide*)
- System settings (see “System settings” in the *PP-100N Administrator’s Guide*)

**Notes**

After you change the Publish Mode, you can change the language setting for messages displayed on the LCD of this product from English to Spanish, French, Italian, Dutch, Portuguese, Japanese, or German. See “Setting the language” on page 62 in this guide if you want to change the language setting.

## Mode change IV

Use the following procedure to change from PIN Controlled Mode to Security Mode, or from Security Mode to PIN Controlled Mode.



Changing the Publish Mode deletes the spool data.

- 1 Check that all jobs are finished.  
See “Checking the job processing status” on page 72 in this guide for details on the check procedure.
- 2 Take out all the discs from Stacker 2.
- 3 Check that the disc cover is locked.
- 4 Log in to EPSON Total Disc Net Administrator.  
See “Logging in to EPSON Total Disc Net Administrator” in the *PP-100N Security User’s Guide* for the login procedure.
- 5 Click the [System settings] tab.

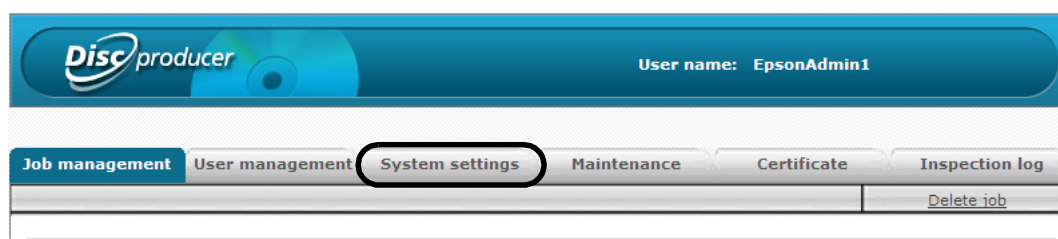

## 6 Change [Mode] to the Publish Mode to use, and click [Save].

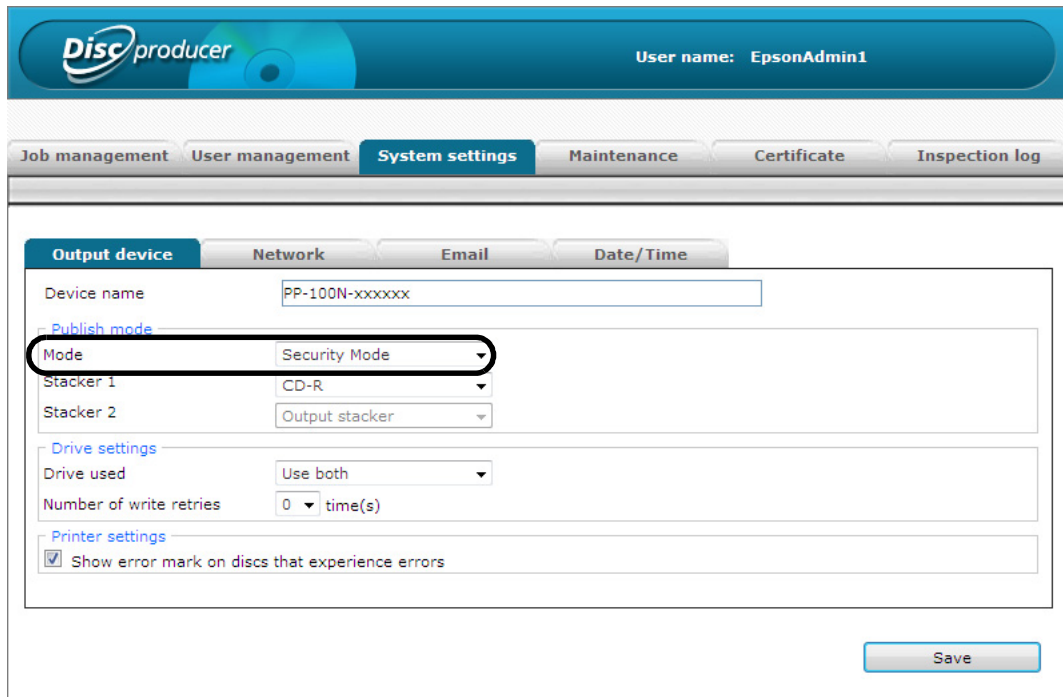

The screenshot shows the 'Disc producer' web interface. The user is logged in as 'EpsonAdmin1'. The 'System settings' tab is active. Under the 'Output device' sub-tab, the 'Mode' dropdown menu is set to 'Security Mode', which is circled in black. Other settings include 'Device name' (PP-100N-xxxxxx), 'Stacker 1' (CD-R), 'Stacker 2' (Output stacker), 'Drive used' (Use both), 'Number of write retries' (0), and a checked checkbox for 'Show error mark on discs that experience errors'. A 'Save' button is located at the bottom right of the settings area.

## 7 Click [OK].

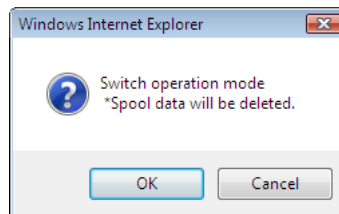

If the Security Mode is set, be sure to check the TOE version after changing the Publish Mode. See "Checking the TOE version (Security Mode only)" on page 114 in this guide for details on the TOE version check procedure.

# Maintaining Your Product

## Backing up and restoring data

This section describes how to back up your product's configuration information, job history, and other data, and how to restore backup data.

### Backing up data

The following data is saved when a backup is performed.

- Job history
- User information
- Output device settings
- Notification email transmission settings
- Date and time settings

Use the following procedure to back up data.



- Backup must always be performed by the administrator.
- The spool data (job data) and network configuration information are not saved to a backup file.
- When you want to create the same disc as an already published disc (see "Convenient features" in the *PP-100N Security User's Guide*), the spool data (job data) on this product's internal hard disk is required. We recommend saving the data file (.tdd file) and write data to a computer via (Save As) of the (File) menu for files of EPSON Total Disc Maker.

- 1 Log in to EPSON Total Disc Net Administrator.  
See "Logging in to EPSON Total Disc Net Administrator" in the *PP-100N Security User's Guide* for the login procedure.
- 2 Click the [Data] tab on the [Maintenance] screen.

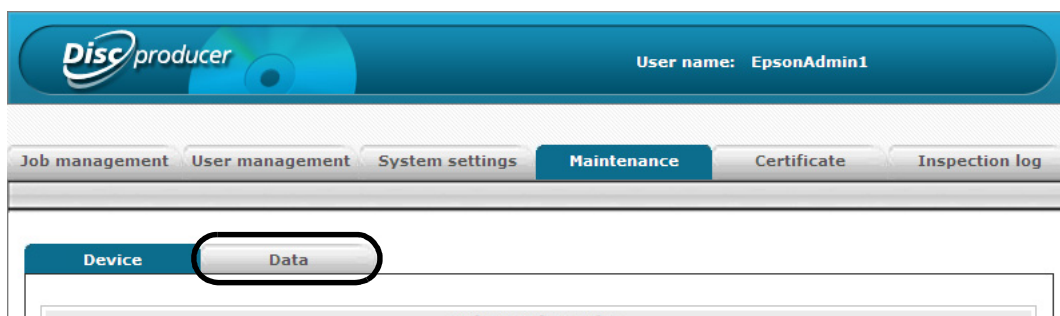

### 3 Click [Backup].

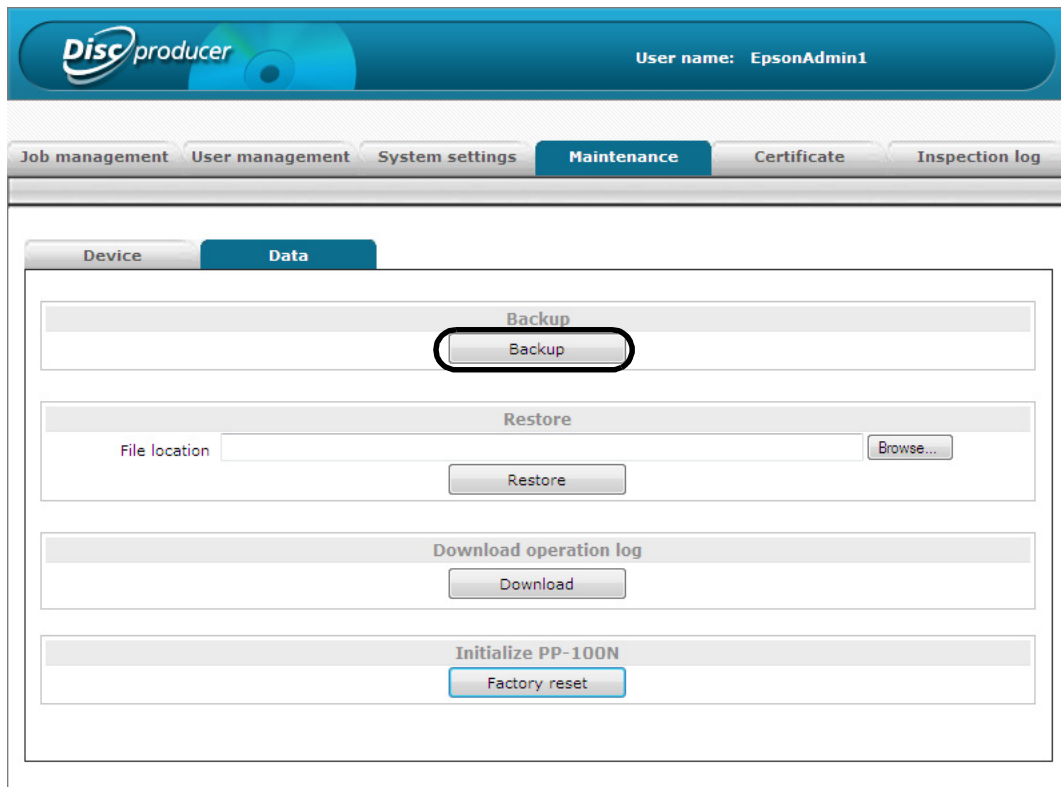

### 4 Click [OK].

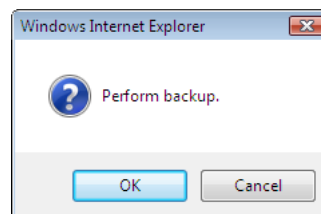

### 5 Specify the save location for the backup file, and then save the backup file.



The backup file contains the password and PIN as well as important security information, including disc publishing history. (The password and PIN are encrypted when stored.) This file should be carefully managed by the administrator.

## Restoring data

Use the following procedure to restore a backup file created in “Backing up data” on page 104 of this guide.



- If you perform a restoration, the restored data overwrites configuration data other than the network configuration information and maintenance information, and overwrites the job history.
- A backup file of a different Publish Mode cannot be restored.

- 1** Log in to EPSON Total Disc Net Administrator.  
See “Logging In to EPSON Total Disc Net Administrator” in the *PP-100N Security User’s Guide* for the login procedure.
- 2** Click the [Data] tab on the [Maintenance] screen.
- 3** Click [Browse] to specify the backup file, and click [Restore].

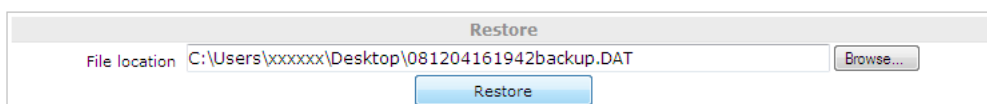

- 4** Click [OK].

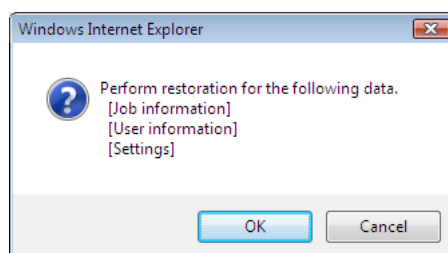

The BUSY LED flashes, and the restoration begins.  
When the BUSY LED goes out, the restoration is finished.

## Restoring to initial state

This section describes how to restore the product to the initial state.



- The product should be restored to the initial state by the administrator, and should not be left unattended until the work is finished.
- Before starting work to restore the product to the initial state, perform a backup (see “Backing up data” on page 104 in this guide) as necessary. Restoring the product to the initial state deletes all of the set information, including the user information and system settings, as well as all job history. The backup file can be restored (see “Restoring data” on page 106 in this guide) after initialization is finished.

### Notes

Even if the product is restored to the initial state, the product’s usage status data is not deleted. See “Checking maintenance information” on page 111 in this guide for details on the usage status.

There are two ways of restoring the product to the initial state as follows:

- Performing the operation on a PC
- Performing an operation with the product’s control panel

### Performing the operation on a PC

- 1 Check that all jobs are finished.  
See “Checking the job processing status” on page 72 in this guide for details on the check procedure.
- 2 Take out all the discs from Stacker 2.
- 3 Log in to EPSON Total Disc Net Administrator.  
See “Logging in to EPSON Total Disc Net Administrator” in the *PP-100N Security User’s Guide* for the login procedure.
- 4 Click the [Data] tab on the [Maintenance] screen.

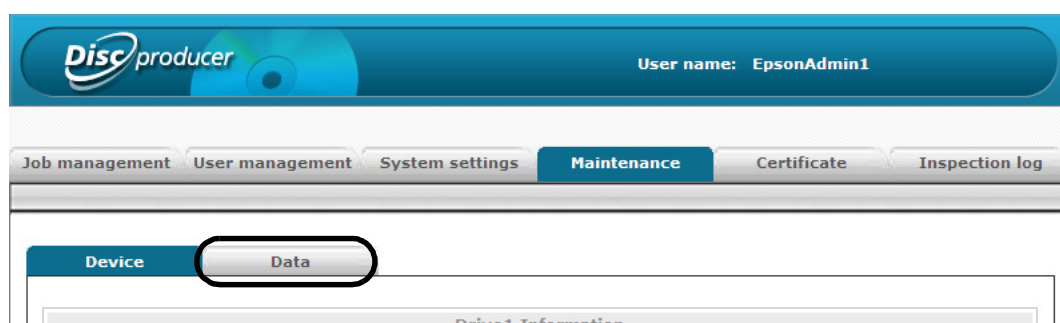

5 Click [Factory reset].

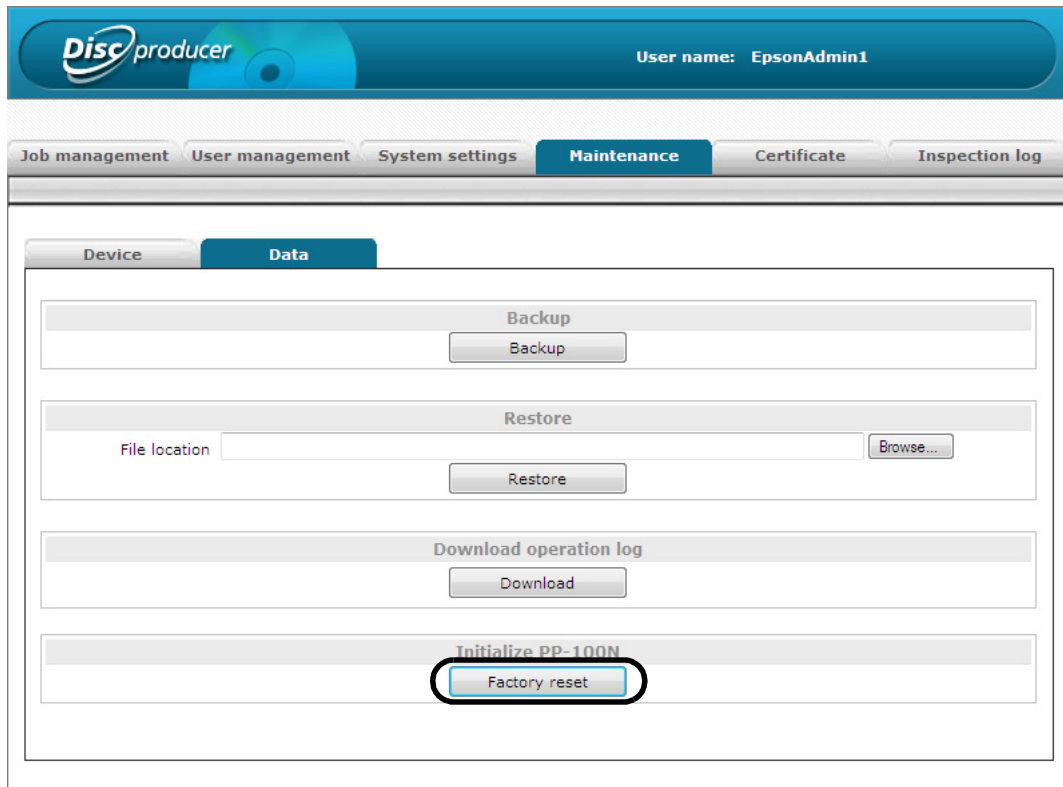

6 Click [OK].

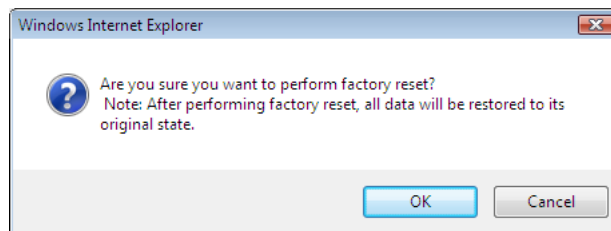

The BUSY LED flashes, and initialization begins. Initialization takes two to three minutes.



Never turn the power off during initialization.

When initialization is finished, the mode selection screen appears on the LCD.

## Performing an operation with the product's control panel

- 1 Check that all jobs are finished.  
See "Checking the job processing status" on page 72 in this guide for details on the check procedure.
- 2 Take out all the discs from Stacker 2.
- 3 Press the MENU button.  
The top menu appears.
- 4 Use the ▲/▼ button to display [Initialize], and press the ↻ button.

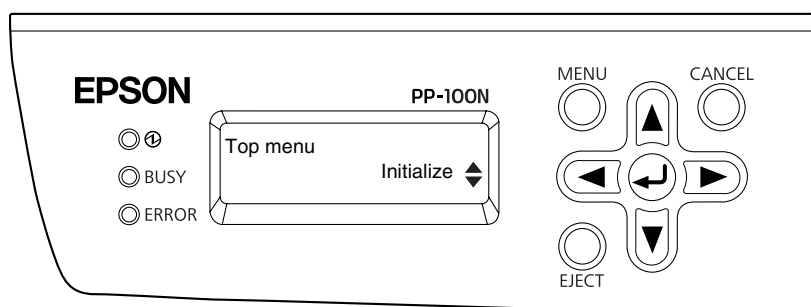

- 5 Use the authentication keypad to enter the user number, and press the Enter key.

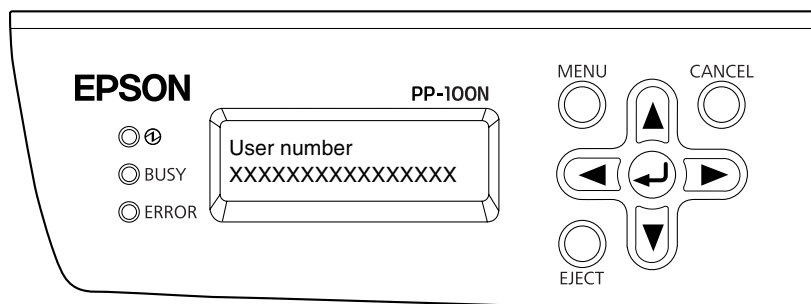

- 6 Use the authentication keypad to enter the PIN, and press the Enter key.

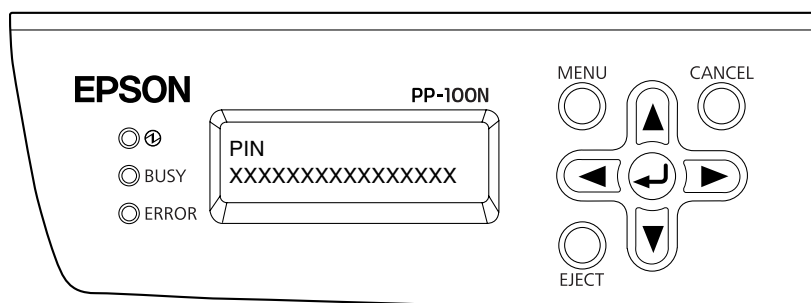

7 When the confirmation message appears, press the  button.

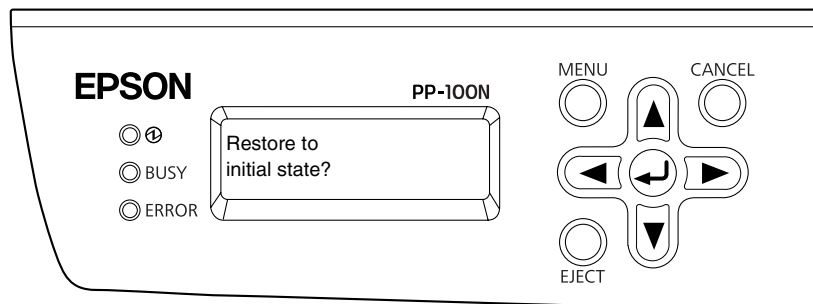

The BUSY LED flashes, and initialization begins. Initialization takes two to three minutes.



Never turn the power off during initialization.

**Notes**

If (Receiving job Cannot proceed) appears on the LCD, wait until job processing is finished and then try again.

When initialization is finished, the mode selection screen appears on the LCD.

# Checking maintenance information

This section describes how to check information that is useful when carrying out maintenance and providing support for this product.

## Checking device information

Use the following procedure to check the usage status of the internal drives and the number of published discs.

- 1 Log in to EPSON Total Disc Net Administrator.  
See "Logging in to EPSON Total Disc Net Administrator" in the *PP-100N Security User's Guide* for the login procedure.
- 2 Click the [Maintenance] tab.

The screenshot shows the EPSON Total Disc Net Administrator web interface. The top navigation bar includes the 'Disc producer' logo and the user name 'EpsonAdmin1'. Below the navigation bar, the 'Maintenance' tab is selected and highlighted. The main content area displays a 'Job status list' table with search options and a list of jobs.

**Search options:**

- Search target: Date published
- Date: December 3, 2008
- Status: All

**Job status list table:**

	Date published	Job name	Status	Publisher	
<a href="#">Details</a>	Dec 3, 2008	DVD_Video	Publishing	EpsonUser1	
<a href="#">Details</a>	Dec 3, 2008	sample_data	Waiting to be ejected	EpsonUser1	
<a href="#">Details</a>	Dec 2, 2008	Untitled	Completed	EpsonUser2	
<a href="#">Details</a>	Dec 2, 2008	20090101	Completed	EpsonUser1	

1/1

The usage statuses of drivers 1 and 2, and the number of published discs appear in the [Device] screen.

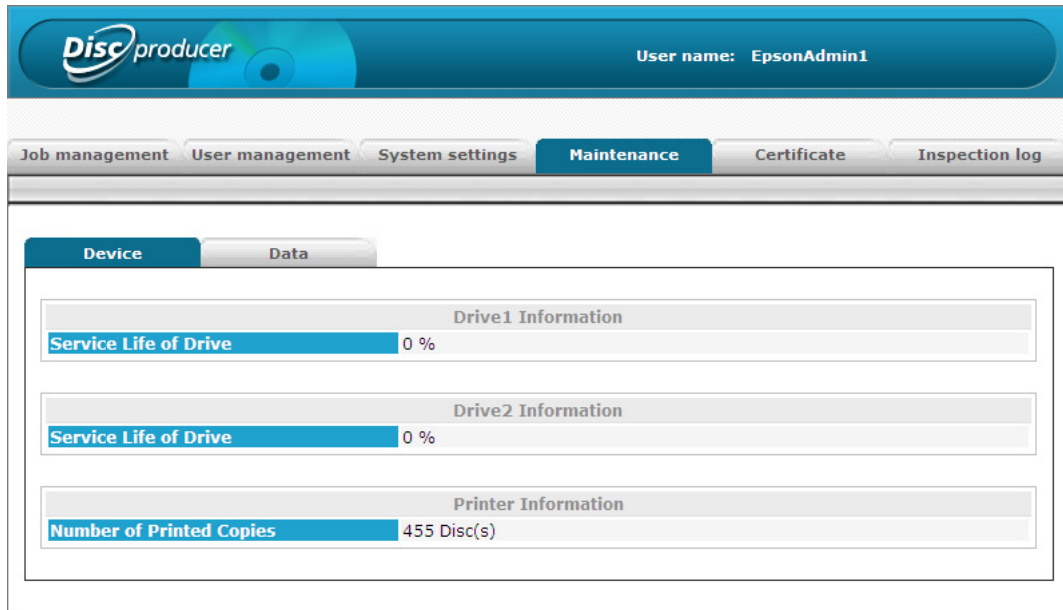

The screenshot displays the 'Disc producer' software interface. At the top, the user name is 'EpsonAdmin1'. The main navigation bar includes 'Job management', 'User management', 'System settings', 'Maintenance' (selected), 'Certificate', and 'Inspection log'. Below this, the 'Device' tab is active, showing three information panels:

Drive1 Information	
Service Life of Drive	0 %

Drive2 Information	
Service Life of Drive	0 %

Printer Information	
Number of Printed Copies	455 Disc(s)

## Downloading operation log

The history of operations and actions on this product are recorded as an operation log. You can download the operation log file for 30 days of operation. Use the operation log file for maintenance and support.

Use the following procedure to download the operation log file.

- 1 Log in to EPSON Total Disc Net Administrator.  
See “Logging in to EPSON Total Disc Net Administrator” in the *PP-100N Security User’s Guide* for the login procedure.
- 2 Click the [Data] tab on the [Maintenance] screen.

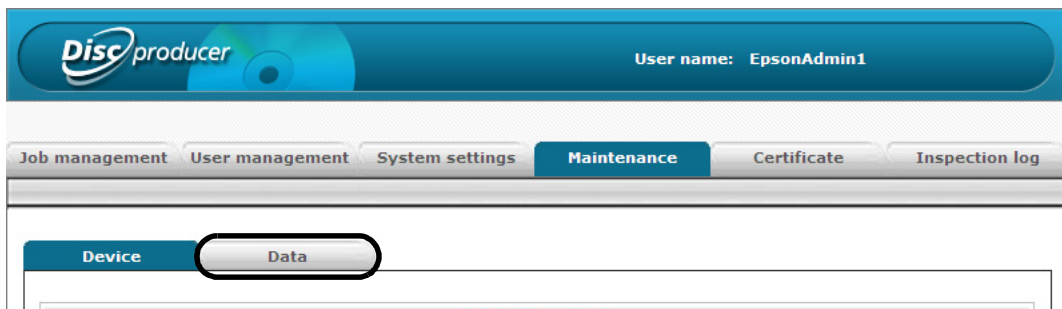

- 3 Click [Download].

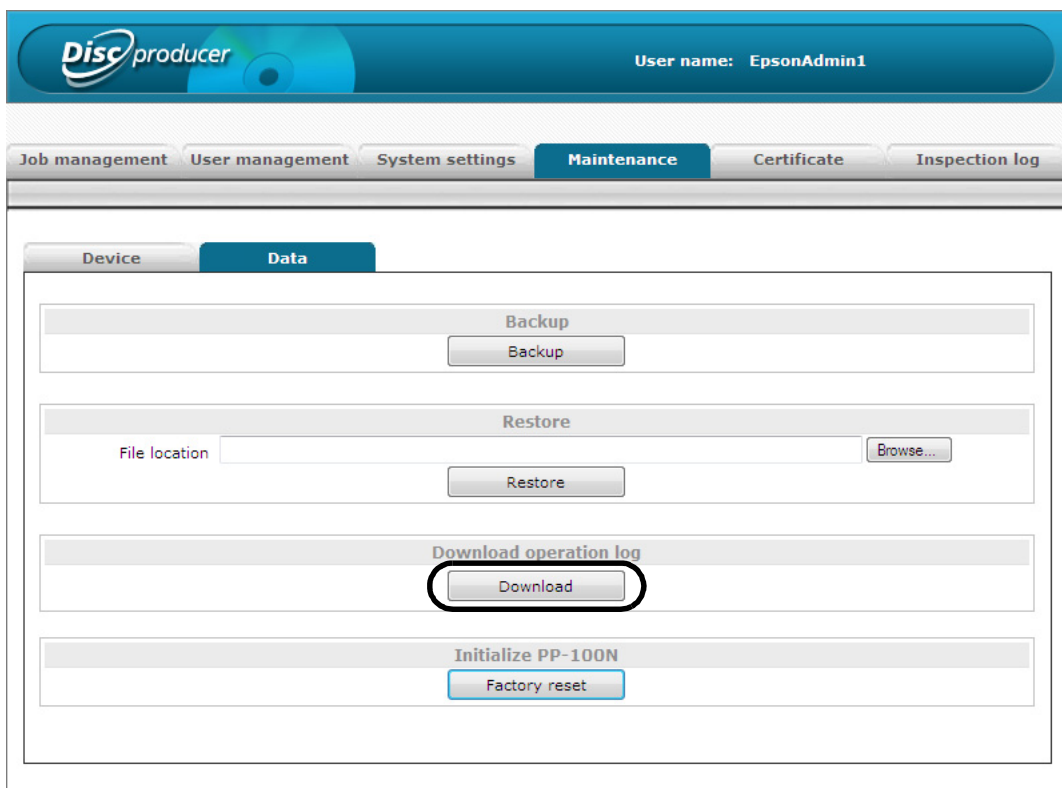

- 4 Specify the save location for the operation log file, and then save the operation log file.

## Checking the TOE version (Security Mode only)

The security control mechanism of this product is called TOE. Use the following procedure to check the TOE version.

- 1 Press the MENU button.  
The top menu appears.
- 2 Use the ▲/▼ button to display [Version], and press the ↵ button.

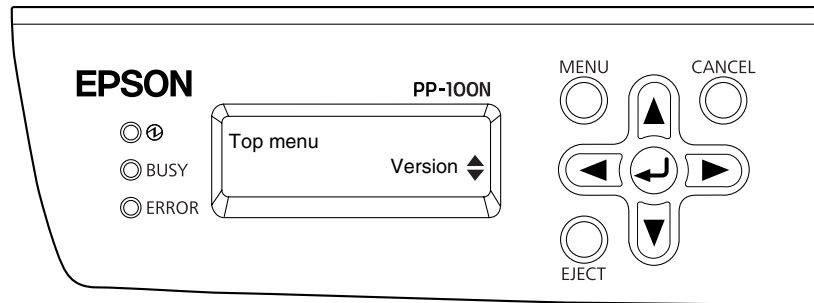

- 3 Use the ▲/▼ button to display the TOE version.

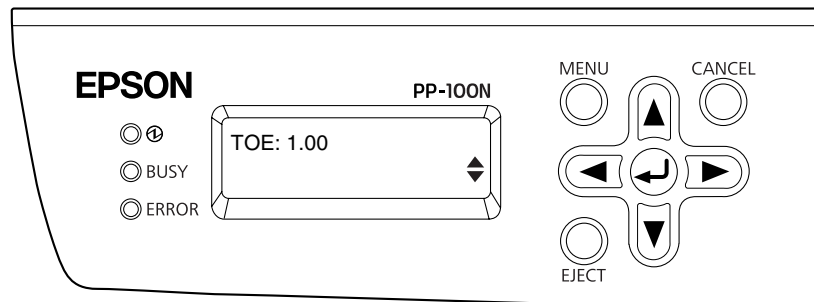



Check that the TOE version is 1.00.

## Starting Service Mode

If instructed by service staff during, for example, a maintenance service, the administrator himself should follow the procedure below to perform the operation to switch to the service mode.

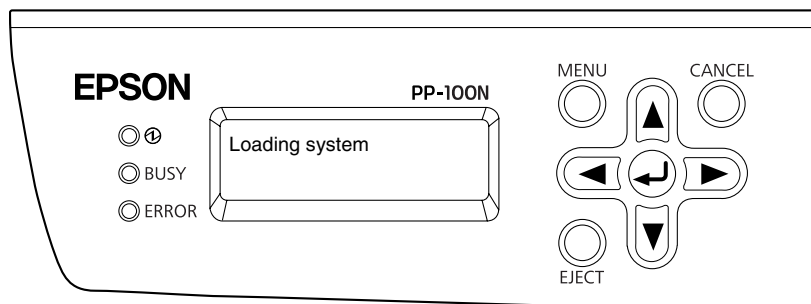
- 1 Make sure that the power is turned off.
- 2 Turn the power on.
- 3 Press the CANCEL button while the following message is displayed (five-second period).



- 4 When the confirmation message appears, press the  button.

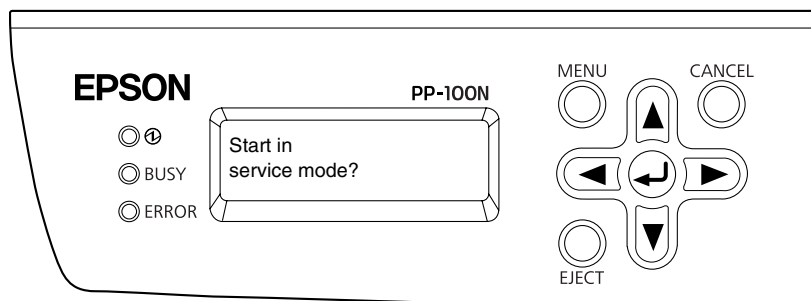

- 5 Use the authentication keypad to enter the user number, and press the Enter key.

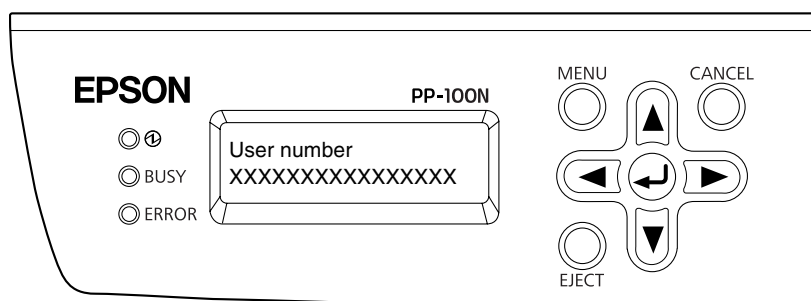

6 Use the authentication keypad to enter the PIN, and press the Enter key.

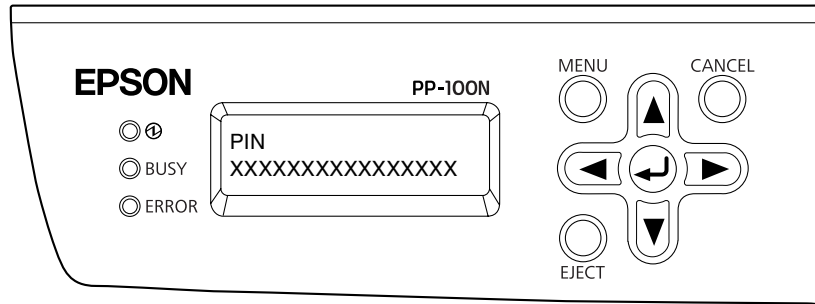

7 When the service mode starts, [Service mode] appears.

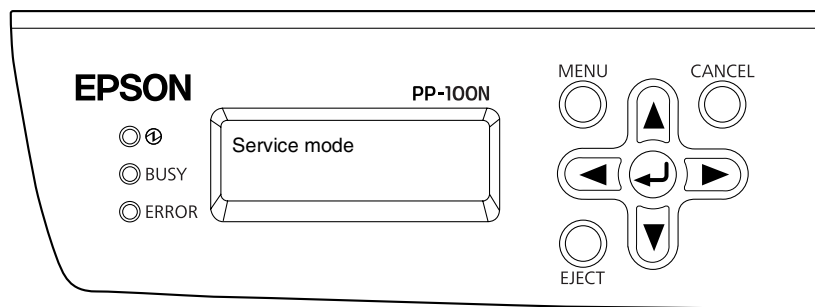

Turn the power off and then back on to start the product in the original Publish Mode.

## Precautions for transporting your product

When transporting this product, be sure to use the original box and protective materials to protect it from an impact, etc. See *PP-100N Security Setup Guide* for details on the handling of protective materials.

- Make sure that no discs remain inside the product.
- Never remove the ink cartridge(s) currently in use. The print head may dry out, and printing may become no longer possible.
- The disc cover key should not be transported with the product. It should be kept by the administrator.
- When attaching protective materials and transporting the product, do not tilt the product or turn it upside down. Make sure that it is oriented horizontally.
- Make sure that the product is lifted by two people.

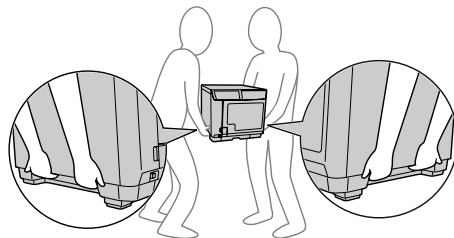

The weight of this product is approximately 25.0 kg. When this product is lifted, it should be lifted on both sides by two people holding the recesses on the sides as shown in the illustration on the left. Holding any part other than the ones indicated in the illustration on the left when carrying the product may result in damage to the product. In particular, carrying the product while the disc cover, ink cartridge cover, or Stacker 4 is open may

result in the product being dropped, or deformed and damaged.

Furthermore, when putting down this product, take care not to trap a finger between the product and installation surface.

- When lifting this product, make sure that, you sufficiently bend your knees, and your posture is such that excessive stress is not placed on your body. An unnatural posture when lifting the product may result in an injury, or the product being damaged.
- When moving the product, do not tilt it 10 or more degrees in a forward, backward direction, or sideways direction. The dropping or other mishandling of the product may result in an accident.
- Do not place a heavy object on the top of the product. Subjecting this product to excessive force may result in a malfunction. However, it is possible to place one unit of this product on top of another. In such a case, make sure the tops and bottoms are oriented the same, and the exterior of the units are aligned. At the same time, take sufficient care to prevent a unit from dropping or falling. Also, do not place more than one unit on top of another.

- 1** Restore the product to the initial state.  
See "Restoring to initial state" on page 107 in this guide for how to restore the product to the initial state.
- 2** Press the power button to turn off the power.
- 3** After the Power LED goes out, disconnect the power cord and Ethernet cable.
- 4** Remove the authentication keypad.  
See "Connecting the authentication keypad" on page 21 in this guide for the removal procedure.

- 
- 5** Set the security lock switch to OFF.
  - 6** Attach protective materials to the arm, and secure them with tape.
  - 7** Attach Stacker 1, Stacker 2, and Stacker 3, and secure them with tape.
  - 8** Open the ink cartridge cover, and secure the ink cartridges with tape.
  - 9** Close the ink cartridge cover, the disc cover, and Stacker 4, and secure them with tape.
  - 10** With the bottom of the product facing downwards, place the product into the packing box so that it is oriented horizontally.

# Troubleshooting



- Repair is required if any damage or problems with the product appearance are found. Immediately cancel operation, and contact Customer Support (see “Where to get help” on page 147 in this guide).
- A beeping warning tone sounds if there is a possibility of a security breach. The administrator must immediately resolve problems based on the message shown on the LCD or EPSON Total Disc Monitor and check that no security breach has occurred.







**Notes** Refer to this information together with the Help file for EPSON Total Disc Monitor.



## Error messages and remedies



When a problem occurs with this product, the ERROR LED turns on or flashes, and an error message appears on the LCD. Check the message, and perform the proper remedy.

 The alarm tone sounds.  The warning tone sounds.



Error Message	Remedy	Notification Sound
<b>Arm move error</b>	The arm cannot be moved. <b>Perform the procedure below.</b> <b>1. Turn off the power.</b> <b>2. Open the disc cover, and remove any dust or foreign objects that are inside.</b> <b>3. Turn on the power.</b> If the same error message still appears, repair is required. Please contact Customer Support.	
<b>Cannot unlock disc cover</b>	<b>Press the  or CANCEL button, and perform the unlock operation of the disc cover again.</b> Open the disc cover after “Disc cover can be opened” appears on the LCD. See “Unlocking the disc cover” on page 63 in this guide for the disc cover unlocking procedure.	
<b>Check Stackers 1 &amp; 2</b>	The power was not turned off correctly the previous time. A published disc may still be in Stacker 1 or Stacker 2. <b>Remove all discs if any published discs are in the stackers.</b>	
<b>CMOS Checksum error</b>	If the same error message appears repeatedly, repair is required. Please contact Customer Support. Also, in some cases, the product’s internal clock may not be operating correctly. Check the clock setting, and make the correct setting if necessary. (See “Setting the date and time” on page 54 in this guide.)	



Error Message	Remedy	Notification Sound
<b>Cover unlocked</b> <b>Cannot turn off</b>	<p>Use the procedure below to lock the disc cover, and then turn off the power.</p> <ol style="list-style-type: none"> <li>1. Check if the security lock switch is set to ON.</li> <li>2. Close the disc cover.</li> <li>3. Check that the disc cover is locked.</li> </ol> <p>The power cannot be turned off when the disc cover is unlocked.</p>	
<b>Disc cover open</b>	<p><b>Check that the security lock switch is set to on, and close the disc cover.</b></p>	
	<p>This product is currently operating.</p> <p><b>Check that the security lock switch is set to on, and close the disc cover.</b></p> <ul style="list-style-type: none"> <li>• Do not open the disc cover while a job is being processed (BUSY LED is flashing). This could adversely affect the writing or printing quality.</li> <li>• To ensure safety during arm operation, never insert your hands.</li> <li>• Do not operate any stackers while the arm is moving. This could damage the arm.</li> </ul>	
	<p>The disc cover has been left open for 60 seconds.</p> <p><b>Perform the procedure below.</b></p> <ol style="list-style-type: none"> <li>1. Check if the security lock switch is set to on.</li> <li>2. Close the disc cover.</li> <li>3. Check that the disc cover is locked.</li> </ol>	
	<p><b>Perform the procedure below.</b></p> <ol style="list-style-type: none"> <li>1. Check if the security lock switch is set to on.</li> <li>2. Close the disc cover.</li> <li>3. Check that the disc cover is locked.</li> </ol> <p>Do not open the disc cover while ejecting discs.</p>	
<b>Disc cover unlocked</b>	<p>A period of 10 seconds has elapsed with the disc cover unlocked.</p> <p><b>Perform the procedure below.</b></p> <ol style="list-style-type: none"> <li>1. Check if the security lock switch is set to ON.</li> <li>2. Close the disc cover.</li> <li>3. Check that the disc cover is locked.</li> </ol>	
<b>Disc drop error</b>	<p>The arm dropped the disc while transferring it.</p> <p><b>Perform the procedure below.</b></p> <ol style="list-style-type: none"> <li>1. Press the  button or CANCEL button.</li> <li>2. Remove the dropped discs.</li> <li>3. Turn off the power, and then turn it on again.</li> </ol>	

Error Message	Remedy	Notification Sound
<p><b>Disc feed error DRV 1/2</b></p>	<p>The disc was not transferred properly to the drive.  <b>Perform the procedure below.</b></p> <ol style="list-style-type: none"> <li><b>1. Remove the discs from the drive tray.</b></li> <li><b>2. Take out all published discs.</b></li> <li><b>3. Fully separate and reload the discs in the input stacker.</b></li> <li><b>4. Close the disc cover.</b></li> </ol>	
<p><b>Disc feed error PRN</b></p>	<p>The disc was not transferred properly to the printer.  <b>Perform the procedure below.</b></p> <ol style="list-style-type: none"> <li><b>1. Remove the discs from the printer tray.</b></li> <li><b>2. Fully separate and reload the discs in the input stacker.</b></li> <li><b>3. Close the disc cover.</b></li> </ol>	
<p><b>Disc is not writable</b></p>	<p>Processing of the job is paused.  <b>Perform the procedure below.</b></p> <ol style="list-style-type: none"> <li><b>1. Open the disc cover.</b></li> <li><b>2. Remove the disc that cannot be written or the disc that is already written from the input stacker (Stacker 1).</b></li> <li><b>3. Load a disc that can be written.</b> (See "Writable disc types" in the <i>PP-100N Security User's Guide</i>.)</li> <li><b>4. Close the disc cover.</b></li> </ol> <p>Processing of the job is automatically resumed.</p>	
<p><b>Disc is wrong type</b></p>	<p>Processing of the job is paused. <b>Perform the procedure below.</b></p> <ol style="list-style-type: none"> <li><b>1. Open the disc cover.</b></li> <li><b>2. Remove the disc from the input stacker (Stacker 1) that is a different type from the disc type that was set.</b></li> <li><b>3. Load the correct disc type.</b> (See "Loading discs" on page 67 in this guide)</li> <li><b>4. Close the disc cover.</b></li> </ol> <p>Processing of the job is automatically resumed.</p>	
<p><b>Disc left in Stacker 2</b></p>	<p>A published disc was left inside the product when the power is turned on.  <b>Remove all the discs remaining in Stacker 2.</b></p>	
	<p>An operator forgot to remove a disc in Stacker 2.  <b>Press the  button or CANCEL button to remove all discs remaining in Stacker 2.</b></p>	
<p><b>Disc pickup error (DRV 1/2)</b></p>	<p>The disc in the drive tray cannot be picked up. <b>Turn off the power, and then turn it on again. (The administrator user number and PIN must be entered to turn off the power.)</b> If the same error message still appears, repair is required. Please contact Customer Support.</p>	

Error Message	Remedy	Notification Sound
Disc pickup error (PRN)	The disc in the printer tray cannot be picked up. <b>Turn off the power, and then turn it on again. (The administrator user number and PIN must be entered to turn off the power.)</b> If the same error message still appears, repair is required. Please contact Customer Support.	
Disc pickup error (ST1/2)	The arm cannot pick up the disc in the stacker. <b>If the ERROR LED is flashing, fan the discs of Stacker 1 well, and reload the discs.</b> <b>If the ERROR LED is flashing, turn the product off and then back on again. (The administrator user number and PIN must be entered to turn off the power.)</b> If the same error message still appears, repair is required. Please contact Epson Information Center.	
Disc release error	The arm cannot release the disc. <b>Do not remove the disc by hand. This could damage the arm. Turn off the power of the product, and then turn it on again. During the initialization operation of the product, the arm releases the disc.</b> If the same error message still appears, repair is required. Please contact Customer Support.	
Disc remaining Cannot turn off	<b>Press the  button or CANCEL button to remove all discs remaining in Stacker 2, and then turn off the power.</b> The power cannot be turned off when a published disc is left inside the product.	
Drive tray open/close error	<b>-When the drive tray does not come out-</b> <b>Turn off the power, and then turn it on again. If the drive trays still does not come out, see "Drive tray does not come out" on page 138 in this guide.</b> If the same error message appears again, repair is required. Please contact Customer Support. <b>-When the drive tray does not close-</b> <b>Remove any remaining discs, turn off the power, and then turn on the power again.</b> If the same error message still appears, repair is required. Please contact Customer Support.	
Fan control error	<b>Turn off the power, and then turn it on again. (The administrator user number and PIN must be entered to turn off the power.)</b> If the same error message still appears, repair is required. Please contact Customer Support.	
Ink cartridge cover open	<b>Close the ink cartridge cover.</b>	
	This product is currently operating. <b>Close the ink cartridge cover.</b>	

Error Message	Remedy	Notification Sound
<b>Ink problem (C,LC,LM,M,Y,K)</b>	An invalid ink cartridge is installed. <b>Replace the cartridge of the displayed color.</b> (See "Changing the ink cartridge" in the <i>PP-100N Security User's Guide</i> .)	
<b>Internal drive error (DRV 1/2)</b>	<b>Turn off the power, and then turn it on again. (The administrator user number and PIN must be entered to turn off the power.)</b> If the same error message still appears, repair is required. Please contact Customer Support.	
<b>Internal printer error</b>	<b>Turn off the power, and then turn it on again. (The administrator user number and PIN must be entered to turn off the power.)</b> If the same error message still appears, repair is required. Please contact Customer Support.	
<b>Internal autoloader error</b>	<b>Perform the procedure below.</b> <ol style="list-style-type: none"> <li><b>1. Turn off the power.</b></li> <li><b>2. Open the disc cover, and check if any dust or foreign objects are inside.</b></li> <li><b>3. Turn on the power.</b></li> </ol> If the same error message still appears, repair is required. Please contact Customer Support.	
<b>Invalid state error</b>	<b>Turn off the power, and then turn it on again. (The administrator user number and PIN must be entered to turn off the power.)</b> If the same error message still appears, repair is required. Please contact Customer Support.	
<b>Keypad connection error</b>	<b>Correctly connect the authentication keypad.</b> (See "Connecting the authentication keypad" on page 21 in this guide.)	
<b>No disc ST1</b>	<b>Load discs into the input stacker (Stacker 1).</b> (See "Loading discs" on page 67 in this guide)	
<b>No ink cartridge (C,LC,LM,M,Y,K)</b>	The ink cartridge of the displayed color is not installed, or is not installed correctly. <b>Correctly install the cartridge of the displayed color.</b> (See "Changing the ink cartridge" in the <i>PP-100N Security User's Guide</i> .)	
<b>No stacker ST1, ST2</b>	<b>Load the displayed stacker, and close the disc cover.</b> (See "Installing the stackers" on page 32 in this guide.)	

Error Message	Remedy	Notification Sound
Non-standard ink Continue?	<p>To use the ink cartridge, press the  button (Yes). To change to a Epson brand ink cartridge, press the CANCEL button (No), and change the ink cartridge.</p> <p>Use of non-Epson brand ink cartridges is not recommended.</p> <ul style="list-style-type: none"> <li>• Use of non-Epson brand ink cartridges can result in problems that will not be covered by the warranty.</li> <li>• Epson cannot guarantee the quality and reliability of non-Epson brand products. Repairs for any damage or breakdown of this product due to the use of non-Epson brand products will not be free of charge even if the warranty period is still valid.</li> <li>• This product performs color adjustment based on use of Epson brand ink cartridges. Use of non-Epson brand ink products can adversely affect the printing quality and prevent the product from realizing its maximum performance.</li> <li>• The ink level for non-Epson brand ink products is not displayed in the printer driver or other indicators.</li> </ul> <p>See "Changing the ink cartridge" in the <i>PP-100N Security User's Guide</i> for the ink cartridge changing procedure.</p>	
Print tray open/close error	<p><b>-When the printer tray does not come out-</b>  <b>Turn off the power, and then turn it on again. If the drive trays still does not come out, see "Printer tray does not come out" on page 139 in this guide.</b> If the same error message appears again, repair is required. Please contact Customer Support.</p> <p><b>-When the printer tray does not close-</b>  <b>Remove any remaining discs, turn off the power, and then turn on the power again.</b> If the same error message still appears, repair is required. Please contact Customer Support.</p>	
Printer maint. error	<p>Repair is required.  <b>Please contact Customer Support.</b></p>	
Processing job Cannot turn off	<p>Press the  button or CANCEL button, and turn off the power after job processing is completed. The power cannot be turned off while a job is being processed.</p>	
Replace ink (C,LC,LM,M,Y,K)	<p>The ink in the cartridge is out.  <b>Replace the cartridge of the displayed color. (See "Changing the ink cartridge" in the <i>PP-100N Security User's Guide</i>.)</b></p>	
Replace inkpad	<p>It is time to replace the ink pad.  <b>Please contact Customer Support.</b> The ink pad cannot be replaced by the customer.</p>	

Error Message	Remedy	Notification Sound
<b>Stacker 2 disc height error</b>	<p>The Stacker 2 disc height has changed compared to before the disc cover was opened.</p> <p><b>Press the  button or CANCEL button to remove all discs remaining in Stacker 2.</b></p>	
<b>Stacker 3 installed</b>	<p><b>Remove Stacker 3, and close the disc cover.</b> Stacker 3 is not used in PIN Controlled Mode and Security Mode.</p>	
<b>Stacker 4 full</b>	<p>The initialization operation cannot be performed because Stacker 4 is full.</p> <p><b>Remove the discs from Stacker 4.</b></p>	
	<p>The disc cannot be ejected because Stacker 4 is full.</p> <p><b>Remove the discs from Stacker 4.</b></p>	
<b>Stacker 4 open</b>	<p><b>Close Stacker 4.</b></p>	
<b>Too many discs ST1, ST2</b>	<p><b>Remove excess discs so that the height of the discs in the indicated stacker is below the red line of the stacker, and then close the disc cover.</b></p>	
<b>Too many discs Stacker 1 &amp; 2</b>	<p>The total disc height of Stacker 1 and Stacker 2 exceeds the red line in the stacker.</p> <p><b>Reduce the number of discs in Stacker 1 or remove all the discs from Stacker 2.</b></p>	
<b>Transferred disc detection error</b>	<p>A disc could not be detected after transfer to a printer or drive. <b>Turn off the power, and then turn it on again. (The administrator user number and PIN must be entered to turn off the power.)</b> If the same error message still appears, repair is required. Please contact Customer Support.</p>	
<b>Wait a moment and try again</b>	<p><b>Press the  button or CANCEL button.</b> Do not unlock the disc cover repeatedly within a short time. Wait a moment before unlocking.</p>	
<b>Write error</b>	<p>Processing of the job is paused. <b>See “Disc writing problems” on page 127 in this guide, and after removing the cause of the error, restart the job.</b> (See “Resuming jobs” on page 74 in this guide for the job restarting procedure.)</p>	

## Problems and their remedies

### Power/Control Panel problems

Symptom/Problem Status	Check/Remedy Procedure
The power does not turn on.	<b>Hold down the power button for a moment.</b>
	<b>Is the power plug disconnected from the outlet?</b> Check if the plug is inserted only halfway or inserted at a slant.
	<b>Are you using a power strip or similar device?</b> Insert the power plug directly into the wall outlet.
	<b>Is power being supplied from the outlet?</b> Insert the power plug for another electronic product to check if power is being supplied.
The power does not turn off.	<b>Is the product in one of the states below?</b> The power cannot be turned off when in one of the states below. <ul style="list-style-type: none"> <li>• A job is currently being processed.</li> <li>• A published disc is left in Stacker 2.</li> <li>• The disc cover is open.</li> <li>• The disc cover is not locked.</li> </ul>
	<b>Did you just turn on the power?</b> The power cannot be turned off for about 15 minutes once the power is turned on. The power turns off automatically 15 minutes after "Power off Please wait" appears on the LCD. If you hold down the power button for a moment (at least 3 seconds), the power off process begins immediately.
	<b>Are the power LED and ERROR LED flashing?</b> If the power LED and ERROR LED are flashing, hold down the power button for a moment (at least 3 seconds). If you enter the user number and PIN of the administrator in the user number and PIN input message that appears, the power off process begins immediately.
A rattling sound is made when the power is turned on.	<b>Is there a foreign object (such as blue protective tape for transporting) inside the product?</b> Press the power button to turn off the power, and then open the disc cover and check that there are no foreign objects inside.
"EPSON PP-100N" remains displayed and the product does not work when the power is turned on.	<b>Repair is required.</b> Please contact Customer Support.
ERROR LED flashes/turns on.	<b>An error has occurred.</b> See "Error messages and remedies" on page 119 in this guide.

## Disc writing problems

Symptom/Problem Status	Check/Remedy Procedure
A writing error has occurred.	<p><b>Is the disc scratched or dirty?</b> Scratched or dirty discs cannot be used. Replace with another disc.</p>
	<p><b>The quality of the data recording surface may vary depending on the disc.</b> Replace with another disc and try again.</p>
	<p><b>Is there dust adhering to the filter of the product rear fan?</b> Clean the filter. See "Cleaning the air vents" in the <i>PP-100N Security User's Guide</i> for details.</p>
Unable to write to disc/ Unable to read disc	<p><b>Is the disc being handled correctly?</b></p> <ul style="list-style-type: none"> <li>• Handle the disc correctly by following the disc user's guide.</li> <li>• Do not affix adhesive stickers to the disc. This may make recording and playback of data no longer possible.</li> <li>• Do not use this product in locations with large amounts of dust or smoke. This can cause drive writing errors.</li> </ul> <p>See "Handling discs" in the <i>PP-100N Security User's Guide</i> for details on disc handling.</p>
	<p><b>Was the cover opened or the product jolted during publishing?</b> Do not subject the product to jolts or impacts during disc publishing. The drive may malfunction, or the disc may become unusable. Also, do not open the cover during publishing. This could adversely affect the printing and writing quality of the disc. Pause the job and then open the cover. See "Pausing jobs" on page 73 in this guide for the procedure for pausing jobs.</p>
	<p><b>Is your computer compatible with the operating environment of this product?</b> Use and connect this product to a computer compatible with the operating environment. See "Before installation" in the <i>PP-100N Security User's Guide</i>.</p>
	<p><b>When copying a disc from the drive, are you logged on with a "computer administrator" account (user with administrator privileges)?</b> If you do not log on with a "computer administrator" account, disc copying from the drive cannot be performed. Log on to Windows with a computer administrator account, and perform disc copying from the drive.</p>
	<p><b>Is the printer tray dirty?</b> Clean the printer tray. See "Disc recording surface is stained with ink" on page 143 in this guide for the printer tray cleaning procedure.</p>

**Notes**

If you set (Write Verification) to (Compare) when publishing discs in EPSON Total Disc Maker, you can check whether data was written to the discs correctly. See the Help file for EPSON Total Disc Maker for details.

## Label printing problems

Symptom/Problem Status	Check/Remedy Procedure
<ul style="list-style-type: none"> <li>• Rubbing</li> <li>• Lines or streaks are formed</li> <li>• Blurriness</li> <li>• Text or lines are shaky</li> <li>• Incorrect color tones</li> <li>• Some colors are not printed</li> <li>• Unevenness in the printing</li> <li>• Mosaic-like patterns are printed</li> <li>• Printing is grainy (jagged)</li> </ul>	<p><b>Are the print head nozzles clogged?</b></p> <p>Perform a nozzle check to confirm the status of the print head, and if it is clogged, perform head cleaning.</p> <p>See the information below for further details.</p> <ul style="list-style-type: none"> <li>• Nozzle Check in the <i>PP-100N Security User's Guide</i></li> <li>• Head Cleaning in the <i>PP-100N Security User's Guide</i></li> </ul>
	<p><b>Are you using a recommended ink cartridge (Epson brand product)?</b></p> <p>This product performs color adjustment based on use of Epson brand ink cartridges. Use of non-Epson brand products can result in poor printing quality. Use of Epson brand ink cartridges is recommended.</p>
	<p><b>Are you using an old ink cartridge?</b></p> <p>Use of an old ink cartridge can result in poor printing quality. The usage period for ink cartridges is printed on the packaging of individual ink cartridges. After opening the cartridge, try to use it up within six months.</p>
	<p><b>Is there a difference in the print head gaps during bidirectional printing?</b></p> <p>When bidirectional printing is set, printing is performed at a high speed, and ink is discharged when the print head moves to both the right or left. On rare occasions, however, the printing position when moving from right to left is shifted from the printing position when moving from left to right, leading to shifting of the vertical rule lines and blurred printing results. Use the print head alignment function to check and adjust for differences in the gap.</p> <p>See "Print Head Alignment" in the <i>PP-100N Security User's Guide</i> for details.</p>
	<p><b>Are you using discs with different thicknesses?</b></p> <p>The thickness varies depending on the disc product. When discs with different thicknesses are used, the gaps of the print head can be shifted. Use the print head alignment function to check and adjust for differences in the gap. When publishing multiple discs, the use of the same disc product type is recommended.</p> <p>See "Print Head Alignment" in the <i>PP-100N Security User's Guide</i> for details.</p>
	<p><b>Are you printing on inkjet printer discs?</b></p> <p>The product supports discs for inkjet printers. This product does not support thermal transfer printer discs. Also, the printing quality may vary depending on the quality of the printing discs. Use of Epson authorized CD and DVD discs is recommended.</p> <p>Epson offers specified CD-R and DVD-R discs for all your printing needs.</p>

Symptom/Problem Status	Check/Remedy Procedure
<ul style="list-style-type: none"> <li>• Rubbing</li> <li>• Lines or streaks are formed</li> <li>• Blurriness</li> <li>• Text or lines are shaky</li> <li>• Incorrect color tones</li> <li>• Some colors are not printed</li> <li>• Unevenness in the printing</li> <li>• Mosaic-like patterns are printed</li> <li>• Printing is grainy (jagged)</li> </ul>	<p><b>Is there dirt on the disc?</b></p> <p>Gently wipe off any dust or dirt adhering to the label side using a soft cloth or commercial CD cleaner. Do not use benzene, thinner, or antistatic agents.</p> <p>See "Handling discs" in the <i>PP-100N Security User's Guide</i> for details.</p>
	<p><b>Is the printing surface fully dry?</b></p> <p>Do not let other discs get in contact with the printing surface until the ink on the published disc is dry. Otherwise, marks can be left where contact is made.</p>
	<p><b>Is the ink drying time set too short?</b></p> <p>The ink drying time is the time after label printing is completed until the disc ink is dried in the printer tray. Set a longer ink drying time. See "Printer Driver Settings" in the <i>PP-100N Security User's Guide</i>.</p>
	<p><b>Are you comparing the display on the computer to the printing results?</b></p> <p>The colors shown on the display and the results printed by the printer use different coloring methods, and this produces differences in color tones.</p>
<p><b>Unable to print correctly in the print area of the disc.</b></p>	<p>Set the inside diameter and outside diameter of the print area so that they match the print area of the disc to be printed.</p> <p>See "Printable Area" in the <i>PP-100N Security User's Guide</i> for details. See "Changing the Printable Area" in the <i>PP-100N Security User's Guide</i> for the inside diameter and outside diameter setting procedure.</p>
<p><b>Printing position is shifted.</b></p>	<p>Correct the printing position if it is shifted.</p> <p>See "Printing Position Correction" in the <i>PP-100N Security User's Guide</i>.</p>
<p><b>The disc recording surface is stained with ink.</b></p>	<p><b>Is the ink drying time set too short?</b></p> <p>The ink drying time is the time after label printing is completed until the disc ink is dried in the printer tray. Set a longer ink drying time. See "Printer Driver Settings" in the <i>PP-100N Security User's Guide</i>.</p>
	<p><b>Is the printer tray dirty?</b></p> <p>When the disc recording surface is stained by ink, the printer tray may be dirty. Clean the printer tray.</p> <p>See "Disc recording surface is stained with ink" on page 143 in this guide for the printer tray cleaning procedure.</p>
<ul style="list-style-type: none"> <li>• After printing, the label surface ink is sticky or peels off.</li> <li>• Discs stick together.</li> </ul>	<p><b>Was printing performed outside the recommended print area?</b></p> <p>If printing is performed outside the recommended print area, after printing, the label surface ink may be sticky or peel off, or discs may stick to each other.</p> <p>See "Printable Area" in the <i>PP-100N Security User's Guide</i> for details.</p>

## Password/PIN problems

Symptom/Problem Status	Check/Remedy Procedure
(Incorrect User number or PIN) is displayed on the LCD.	<p><b>Was the user number or PIN entered incorrectly?</b> Enter the correct user number and PIN.</p>
	<p><b>Is the account locked?</b> After three unsuccessful attempts at entering the password or PIN, the account is locked, and the password and PIN cannot be used. Please ask another administrator to remove the account lock. Also, locks on administrator accounts are automatically removed after six hours have passed.</p>
(Expired PIN) is displayed on the LCD.	<p><b>Are the validity periods for the password and PIN expired?</b> Log onto EPSON Total Disc Net Administrator, and change the password and PIN on the Change Password screen that is displayed. See "Changing password and PIN" on page 89 in this guide for the password and PIN changing procedure.</p>
User name or password cannot be used.	<p><b>Was the user name or password entered incorrectly?</b> Enter the correct user name and password. These entries are case sensitive.</p>
	<p><b>Are the validity periods for the password and PIN expired?</b> Log onto EPSON Total Disc Net Administrator, and change the password and PIN on the Change Password screen that is displayed. See "Changing password and PIN" on page 89 in this guide for the password and PIN changing procedure.</p>
	<p><b>Is the account locked?</b> After three unsuccessful attempts at entering the password or PIN, the account is locked, and the password and PIN cannot be used. Please ask another administrator to remove the account lock. Also, locks on administrator accounts are automatically removed after six hours have passed.</p>
You forgot the password or PIN.	<p>Please ask another administrator to change the password and PIN.</p>

## Other problems

Symptom/Problem Status	Check/Remedy Procedure
<p><b>Cannot install software</b></p>	<p><b>Is there enough available HDD space?</b></p> <p>The software cannot be installed unless there is at least 10 GB of available HDD space. Check the amount of available HDD space, and if there is not enough space, increase the amount of available space.</p> <p>In Windows Vista, at least 25 GB of available HDD space is needed to allow the software to run normally.</p>
	<p><b>Are you logged on to Windows with a “computer administrator” account (user with administrator privileges)?</b></p> <p>When using Windows XP or Windows Vista, you must log on with a “computer administrator” account (user with administrator privileges). In Windows Vista, you may be asked for an administrator password or confirmation. When asked for a password, enter the password to proceed with operation.</p> <p>In Windows 2000, log on as a user with administrator privileges (user in the Administrators group).</p>
<p><b>The EPSON Total Disc Net Administrator login screen is not displayed.</b></p>	<p><b>Is the power of the product turned off?</b></p> <p>Turn on the power of the product.</p>
	<p><b>Is the product connected to the network correctly?</b></p> <p>Check that this product and the client computer are connected correctly to the network.</p>
	<p><b>Is the correct address entered?</b></p> <p>Check that the IP address, host name, or FQDN of the product was correctly entered in the Internet Explorer address bar. Be sure to always enter this information after “https://”.</p>
<p><b>A security warning screen is displayed when you try to log into EPSON Total Disc Net Administrator.</b></p>	<p><b>Was the certificate issued by the certificate authority imported correctly?</b></p> <p>Check that the certificate is correctly installed to the client computer. See “Installing digital certificates” on page 56 in this guide for details.</p>
	<p><b>Is the validity period for the certificate expired?</b></p> <p>The certificate has a validity period. Check if the validity period has expired. See “Installing digital certificates” on page 56 in this guide for further details.</p>
	<p><b>Is the publish destination of the certificate being accessed?</b></p> <p>When you attempt to log in to EPSON Total Disc Net Administrator, a security warning screen appears if the product’s IP address, host name, or FQDN entered in the Internet Explorer address bar differs from that of the publish destination. See “Installing digital certificates” on page 56 in this guide for the publish destination setting procedure.</p>





Symptom/Problem Status	Check/Remedy Procedure
<b>The drive cannot be used.</b>	<p><b>Is use of the drive stopped?</b></p> <p>When a write error occurs based on a preset write retry count, use of the drive is automatically stopped, and (Drive operation paused DRV1/2) is displayed on the LCD. See "Output device settings" on page 47 in this guide for the drive use restarting procedure.</p>
<b>Head cleaning does not work.</b>	<p><b>Has an error occurred in the product?</b></p> <p>If an error has occurred, clear the error.</p>
	<p><b>Is there enough ink?</b></p> <p>Head cleaning cannot be performed unless there is enough ink. Replace with a new ink cartridge.</p> <p>See "Changing the ink cartridge" in the <i>PP-100N Security User's Guide</i> for the ink cartridge changing procedure.</p>
<b>The printing speed slowed down during continuous printing.</b>	<p>When printing is performed for an extended period of time, disc transfer and printing may be stopped temporarily. This is for slowing the printing speed to prevent overheating and damage to the product. Although printing can be continued when this occurs, it is recommended that you stop product operation and leave it with the power on for about 30 minutes. (Note that the product does not return to the normal status when the power is turned off.)</p>
<b>Cannot publish discs.</b>	<p>See "When discs cannot be published" on page 135 in this guide.</p>

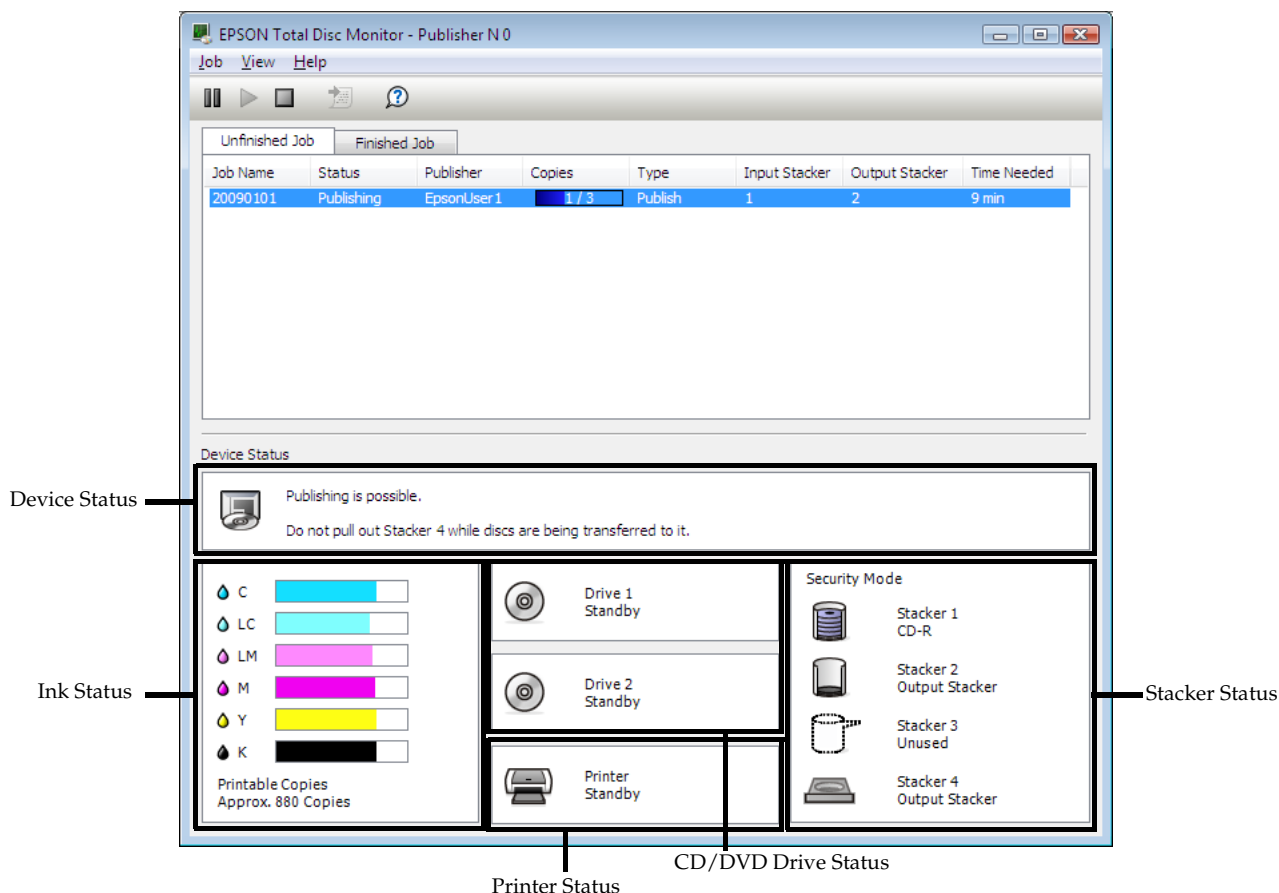

# Checking with EPSON Total Disc Monitor

EPSON Total Disc Monitor is a utility that enables checking of the status of this product (PP-100N) and the remedy procedures for errors.

See “Starting EPSON Total Disc Monitor” in the *PP-100N Security User’s Guide* for details on the EPSON Total Disc Monitor startup procedure.



Device Status	This displays the status of this product (PP-100N), error descriptions and messages. When  or  is displayed, check the product (PP-100N) by referring to the displayed remedy procedure.
Ink Status	This displays the remaining ink level. The ink level is low when  is displayed. Obtain a replacement ink cartridge. The ink should be replaced when  is displayed. Replace with a new ink cartridge. See “Changing the ink cartridge” in the <i>PP-100N Security User’s Guide</i> for the ink cartridge changing procedure. The number of printable labels is an estimate of how many more of the same type of labels as last time can be printed. This value may differ slightly from the actual value due to factors such as the printing data and printing environment. Values of 1000 or more are displayed as “1000 or more,” and quantities fewer than 1000 discs are displayed in 10-disc units.
CD/DVD Drive Status	This displays the CD/DVD drive status. When  is displayed on the drive icon, check the product drive by referring to the displayed message.

Printer Status	<p>This displays the printer status.</p> <p>When  is displayed on the printer icon, check the product printer by referring to the displayed message.</p>
Stacker Status	<p>This displays the stacker status.</p> <p>When  is displayed, either the number of discs in the input stacker is low, or the output stacker is nearly full of discs.</p> <p>If the number of discs in the input stacker is low, obtain new discs.</p> <p>If the output stacker is nearly full of discs, the ejecting of discs is recommended before publishing the next job.</p> <p>When  is displayed, check the stacker and discs by referring to the displayed message.</p>

## ***When discs cannot be published***

If the disc is not published by clicking [Publish] in the Publish view of EPSON Total Disc Maker, or if the product does not work, check the points below.

---

### ***Check 1: Check of EPSON Total Disc Monitor***

*Is an error message displayed in EPSON Total Disc Monitor?*

Check the status of this connected product in EPSON Total Disc Monitor, and perform the remedy if an error has occurred.

See the references below for details on EPSON Total Disc Monitor.

- “EPSON Total Disc Monitor” of *PP-100N Security User’s Guide*
- Help file for EPSON Total Disc Monitor

If performing the above checks still does not fix the problem, check the items below.

---

### ***Check 2: Check of the product***

*Is the power LED turned on?*

If the power LED is not turned on, the power for the product is turned off.

Turn on the power by referring to “Power/Control Panel problems” on page 126 in this guide.

*Is the ERROR LED flashing/turned on?*

If the ERROR LED is flashing/turned on, an error has occurred in the product.

See “Checking with EPSON Total Disc Monitor” on page 133 in this guide for the error checking and remedy procedures.

If performing the above checks still does not fix the problem, check the items below.

---

### **Check 3: Check of connection between the product and computer**

#### *Is the Ethernet cable disconnected?*

Check that the Ethernet cable is connected. Also, check if the Ethernet cable has a broken wire or is bent.

#### *Is the Ethernet cable compatible with the computer and product specifications?*

Check that the Ethernet cable being used is compatible with one of the specifications below.

- 100Base-TX
- 1000Base-T

#### *Are the link speed and Jumbo Frame set correctly?*

If the link speed and Jumbo Frame are set, check that the product settings match the client computer settings.

If performing the above checks still does not fix the problem, check the items below.

---

### **Check 4: Check of printer driver settings**

#### *Is the printer driver installed?*

- 1** Open [Printers and Faxes] (or [Printers]).

**Windows Vista:**

 Click [Start] - [Control Panel] - [Printers], in this order.

**Windows XP:**

In Windows XP Professional, click [Start] - [Printers and Faxes]. In Windows XP Home Edition, click [Start] - [Control Panel] - [Printers and Faxes], in this order.

**Windows 2000:**

Click [Start] - [Settings] - [Printers], in this order.

- 2** Check that this product icon (EPSON PP-100NPRN) is found in [Printers and Faxes] (or [Printers]).

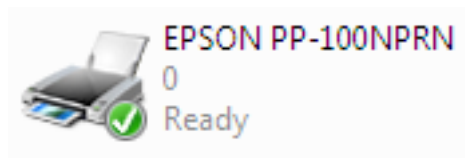

If the icon is not found, the printer driver is not installed. See "Installation" in the *PP-100N Security User's Guide* to install the printer driver.

### *Is the Print Manager status set to Pause?*

If [Paused] is displayed for the product's icon (EPSON PP-100NPRN), right-click the icon and click [Resume Printing].

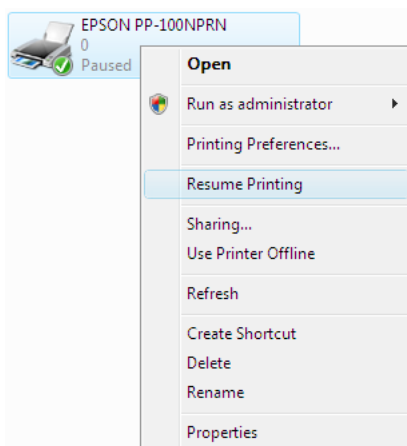

If performing all of the above checks still does not resolve the problem, the software may not be installed correctly. Uninstall (delete) the software, and then reinstall.

See “Software Uninstallation” in the *PP-100N Security User’s Guide* for the software uninstallation procedure.

See “Installation” in the *PP-100N Security User’s Guide* for the software installation procedure.

Please contact Customer Support if this still does not resolve the problem. When making inquiries, please provide information about your operating environment (including the computer model, names and versions of software applications, and other peripheral models), name of this product, and its serial number.

## Disc does not come out

Perform the procedure below if the disc cannot be ejected because the drive tray or printer tray does not come out.

### Drive tray does not come out

Turn the power of the product off and then on again. If the drive tray still does not come out, perform the procedure below.

- 1 Press the power button to turn off the power.
- 2 After the power LED goes off, disconnect the power plug from the outlet.
- 3 Wait about one minute until the disc stops rotating, and then open the disc cover.
- 4 Insert a hard pin into the eject hole of the drive to open the tray.

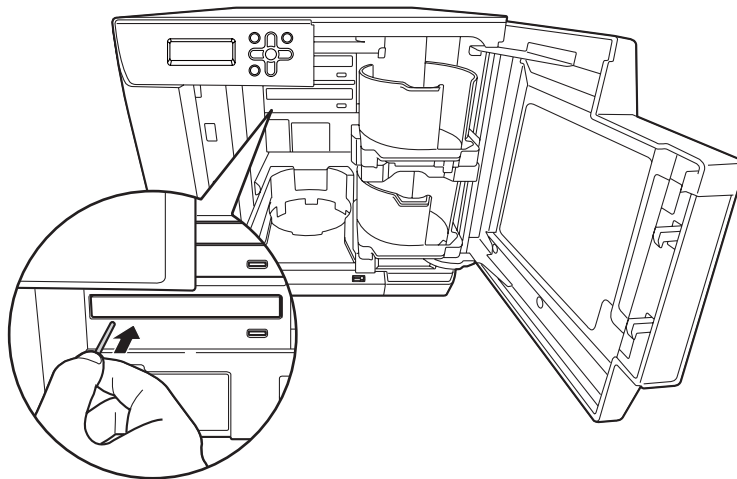

When inserting the pin into the eject hole, be sure that the power of the product is off.

- 5 Pull out the disc, and gently push in the drive tray to close.



The product can be damaged if you leave the drive tray open when turning on the power of the product.  
Be sure to always close the drive tray.

- 6 Close the disc cover.
- 7 Insert the power plug into the outlet, and turn on the power.

## *Printer tray does not come out*

Turn the power of the product off and then on again. If the printer tray still does not come out, perform the procedure below.

- 1** Press the power button to turn off the power.
- 2** After the power LED goes off, disconnect the power plug from the outlet.
- 3** Open the disc cover.

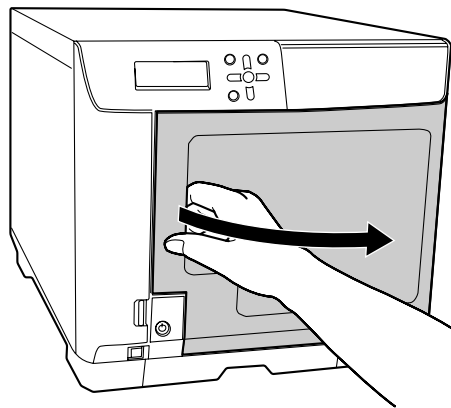

- 4** Remove the two screws on the product rear that secure the top plate.

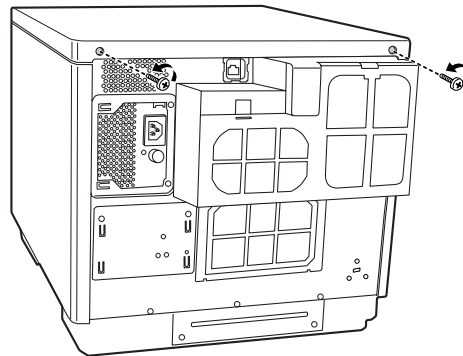

**5** Grasp the fixture inside the product top, and slide it backwards slightly.

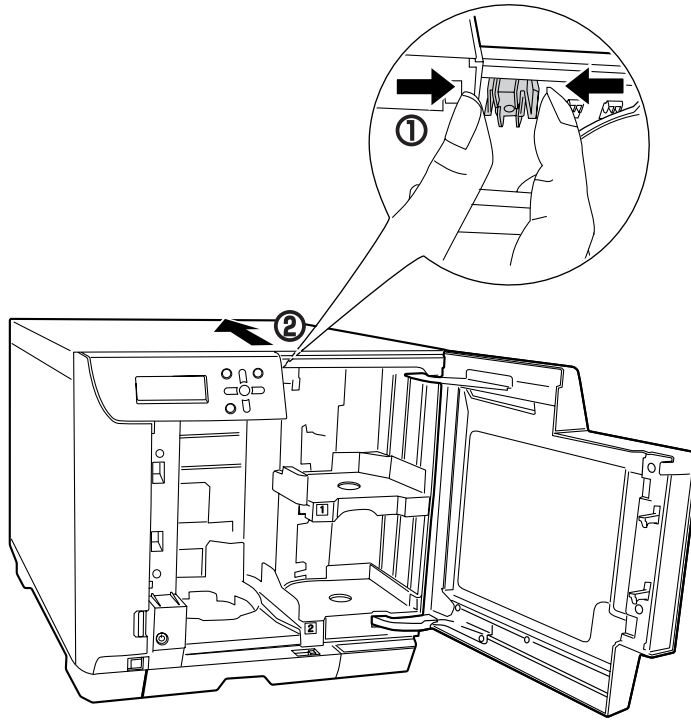

**6** Remove the top plate.

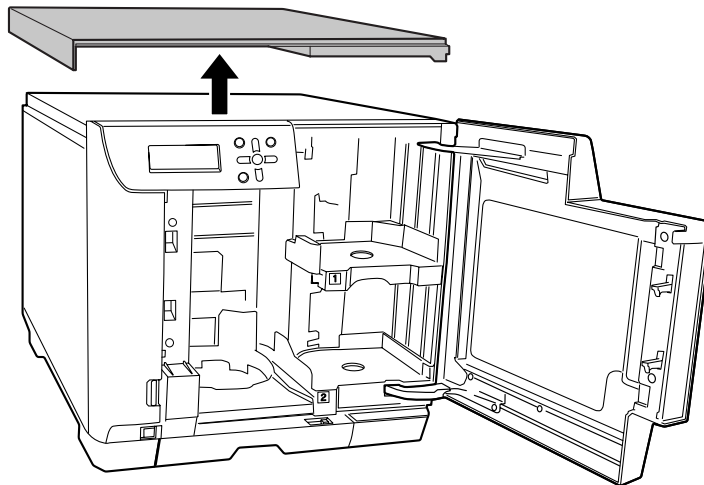

- 7** Remove the four screws on the product rear, and then remove the air vent cover.

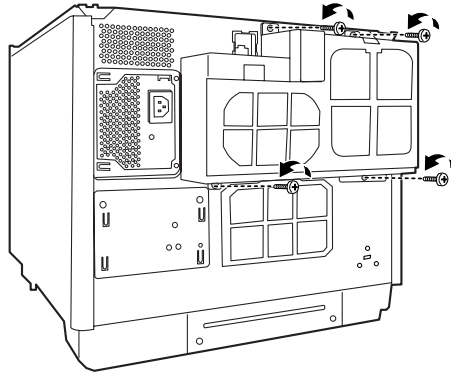

- 8** Remove the screw, and then remove the rear printer cover.  
 If the disc can be removed, eject the disc and attach the rear printer cover. If the disc cannot be removed, proceed to the procedure below.

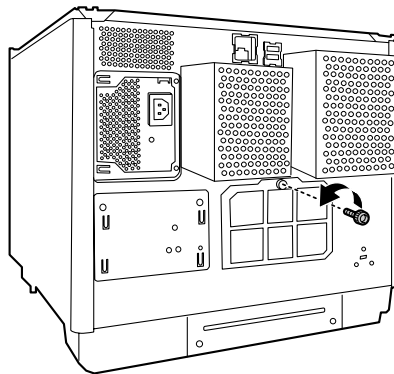

- 9** Grasp the fixture as shown in the figure below, and pull out the printer tray towards you.

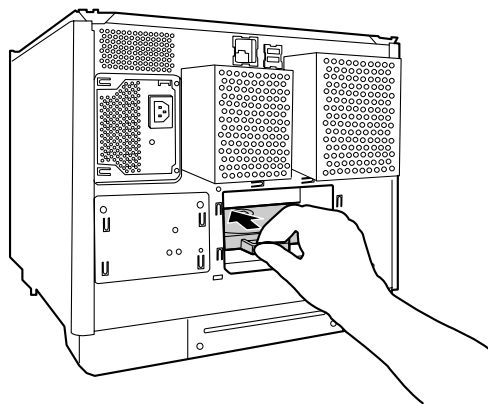

**10** Pull out the printer tray.

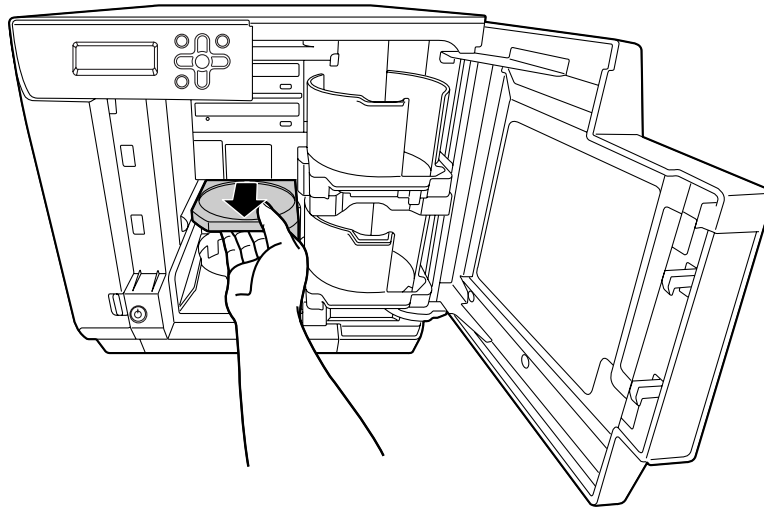

**11** Remove the disc, and close the disc cover.

The printer tray automatically closes when the power is turned on.

**12** Reattach the rear printer cover, air vent cover, and top plate.

**13** Insert the power plug into the outlet, and turn on the power.

## ***Disc recording surface is stained with ink***

When the disc recording surface is stained with ink, the printer tray may be dirty. Clean the printer tray by following the procedure below.

- 1** Press the power button to turn off the power.
- 2** After the power LED is off, disconnect the power plug from the outlet.
- 3** Open the disc cover.

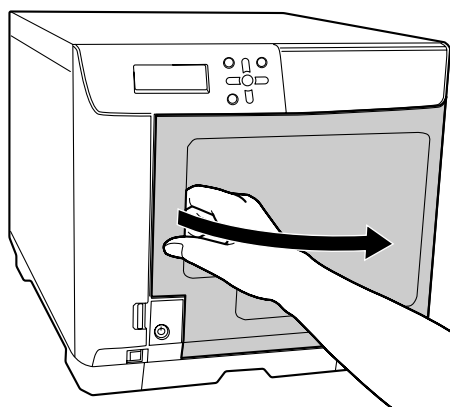

- 4** Remove the two screws on the product rear that secure the top plate.

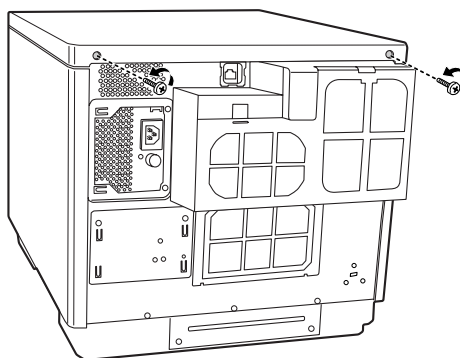

- 5 Grasp the fixture on the top plate, and slide it backwards slightly.

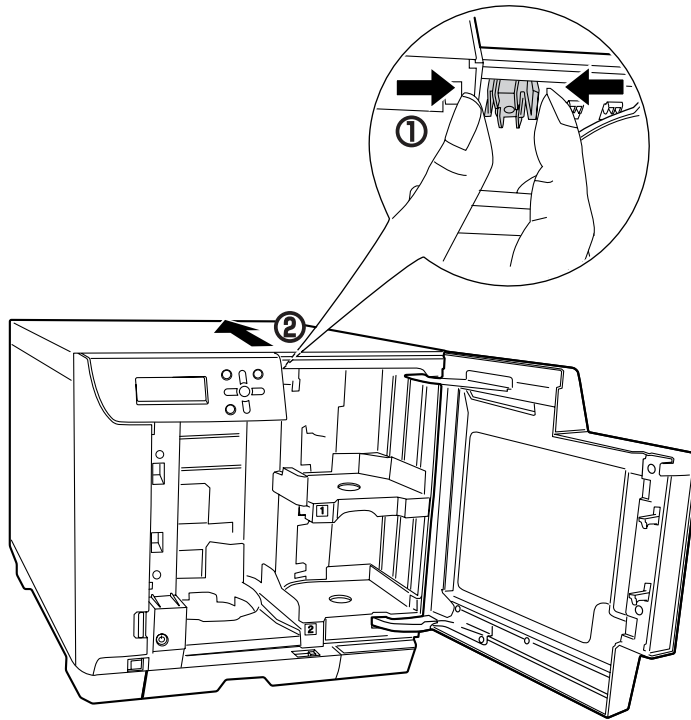

- 6 Remove the top plate.

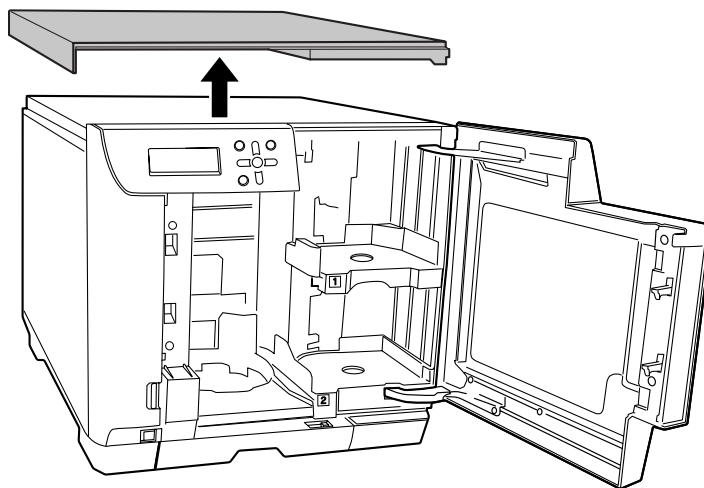

- 7 Remove the four screws on the product rear, and then remove the air vent cover.

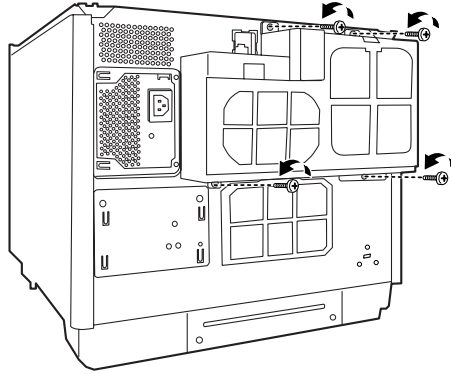

- 8 Remove the screw, and then remove the rear printer cover.

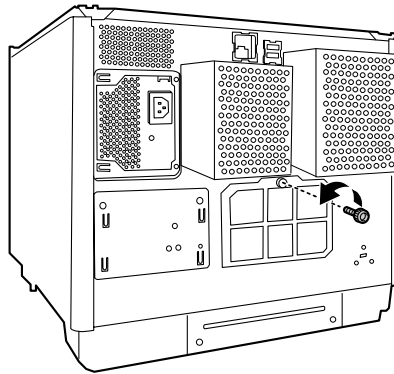

- 9 Grasp the fixture as shown in the figure below, and pull out the printer tray towards you.

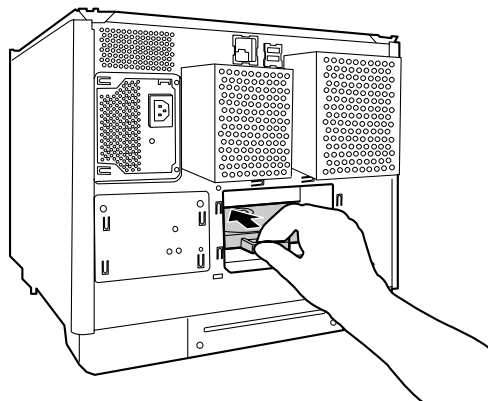

**10** Pull out the printer tray.

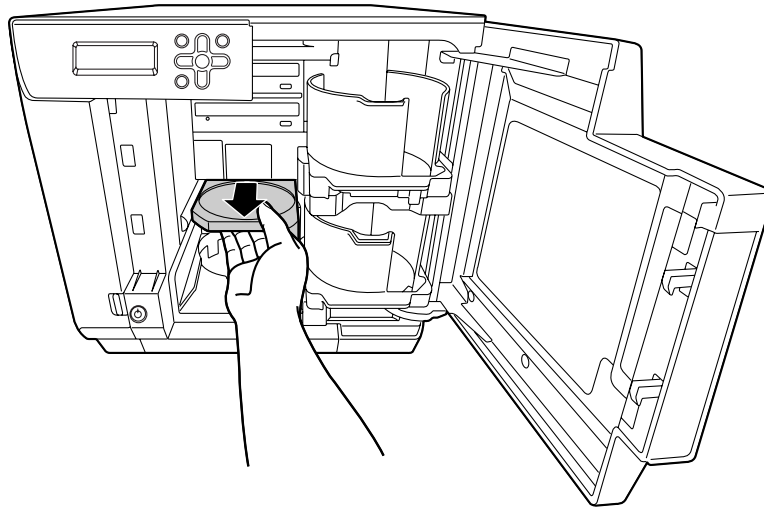

**11** Use a soft cloth to wipe off any dirt on the printer tray.

**12** Close the disc cover.

The printer tray automatically closes when the power is turned on.

**13** Reattach the rear printer cover, air vent cover, and top plate.

**14** Insert the power plug into the outlet, and turn on the power.

# Appendix

## Where to get help

### *Before contacting Epson*

If your Epson product is not operating properly and you cannot solve the problem using the troubleshooting information in your product documentation, contact customer support services for assistance. If customer support for your area is not listed below, contact the dealer where you purchased your product.

Customer support will be able to help you much more quickly if you give them the following information:

- Product serial number  
(The serial number label is usually on the back of the product.)
- Product model
- Product software version  
(Click **Help**, **About EPSON Total Disc Maker**.)
- Brand and model of your computer
- Your computer operating system name and version
- Names and versions of the software applications you normally use with your product

### *Help for users in the United States and Canada*

Contacts for information, support, and services are:

Discproducer Technical Support: 562-276-1360

Location: Epson America Inc.

Web site URL: <http://www.discproducer.epson.com>

This site will provide the end user with access to the latest drivers and FAQs.

### *Help for users in Europe (EMEA)*

Contacts for information, support, and services are:

Web site URL: <http://www.discproducer.epson-europe.com>

Or contact your local distributor or Epson sales company.

If you need the latest drivers, FAQs, manuals, or other downloadable, access the site at:

<http://download.epson-discproducer.com>

# Product specifications

## Basic specifications

### External dimensions and weight

Item	Description
External dimensions	377 mm (W) x 514 mm (D) x 348 mm (H)
Weight	Approx. 25.0 kg (including the stackers and ink cartridges, but not including the power cord and discs)



Since this product uses galvanized sheet metal, rusting may occur at the edges, but this will not harm the functionality of the product.

<External View>

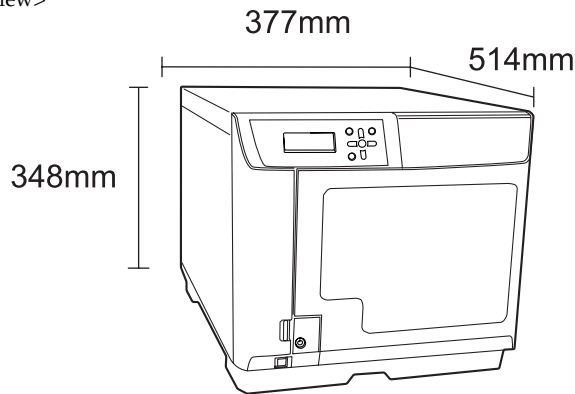

### Overall specifications

Item		Description
Job processing speed	Write and print	CD 30 discs per hour Conditions: When using Epson specified CD-Rs, drive speed of 40x, writing data of 600 MB, and speed/bidirectional printing
		DVD 15 discs per hour Conditions: When using Epson specified DVD-Rs, drive speed of 12x, writing data of 3.8 GB, and speed/bidirectional printing
	Print only	Speed 60 discs per hour Condition: When bidirectional printing
		Quality 40 discs per hour Condition: When bidirectional printing



- The above processing capacities do not include the time for transferring a job via the network.
- Depending on the operating environment and discs used, the write speed may become slower than the set speed.

## Printing specifications

Item		Description
Printing method		On demand inkjet
Head	Number of nozzles	Black : 180 nozzles
		Cyan : 180 nozzles
		Magenta : 180 nozzles
		Yellow : 180 nozzles
		Light cyan : 180 nozzles
		Light magenta : 180 nozzles
Printing resolution		Speed 1,440 x 720 dpi* Quality 1,440 x 1,440 dpi
Printing direction		Bidirectional, unidirectional

\* dpi: number of dots per 25.4 mm (dots per inch)

## Ink cartridge

Item		Description	
Form		Separate ink cartridge for each color	
Color		Black, cyan, magenta, yellow, light cyan, light magenta	
Recommended expiration date		Use within the expiration date written on each individual packaging box. Use within 6 months of opening the package.	
Temperature	When stored packaged individually	-20°C~40°C	Within 1 month at 40°C
	When installed in the product	-20°C~50°C	Within 1 month at 50°C
	When transported packaged individually	-20°C~60°C	Within 5 days at 60°C
Dimensions		42.0 mm (W) x 83.0 mm (D) x 26.4 mm (H)	
Ink		Dye-based ink	

## Drive specifications

Item	Description	
Number of drives installed	2 drives	
Loading type	Tray	
Write speed	CD-R	40x/32x/24x/16x/10x/4x
	DVD-R	12x/8x/6x/4x/2x/1x
	DVD+R	12x/8x/6x/4x/2.4x
	DVD-R DL	8x/6x/4x/2x
	DVD+R DL	8x/6x/4x/2.4x



- CD/DVD discs created with this product's drive may not be able to be recognized, played, and read depending on the compatibility of the drive or player.
- Do not subject the product to vibration or impacts while a disc is being read or written. The drive may malfunction, or the disc may become unable to be played.
- Do not insert a flat-tip screwdriver, clip, or other foreign object into the CD/DVD drive. Doing so may result in a malfunction.
- Depending on the operating environment and discs used, the writing speed may become slower than the set speed. (This is to ensure recording quality is maintained.)

## Electrical specifications

Item		Description
Rated voltage		AC 100 to 240 V
Rated frequency		50 to 60Hz
Rated current		1.5 A
Power consumption	Average during operation	Approx. 86 W
	Average during standby	Approx. 55 W
Power cord		Power cord (supplied with product)

## ***Standards and approvals***

<b>Item</b>	<b>Description</b>
Safety	UL60950-1 CAN/CSA-C22. 2 No. 60950-1
EMC	FCC Part 15 Subpart B Class A CAN/CSA-CEI/IEC CISPR 22 Class A
Low voltage directive 2006/95/EC	EN60950-1
EMC directive 2004/108/EC	EN55022 Class A EN61000-3-2 EN61000-3-3 EN55024

## ***Lifetime***

Epson estimates lifetime for components of this product to be as follows:

### *Expected Lifetime:*

- Ink pad life: About 10,000 to 40,000 discs printed
- Burner life: About 8,000 to 30,000 discs burned

The product's ink pad is expected to become saturated and need replacing after printing about 10,000 to 40,000 discs. The burner life estimate is the combined life for the two burners, with the low estimate based on burning DVDs only, and the high estimate based on burning CDs only. Expected lifetimes are only estimates. Actual results will vary based on such factors as images printed, print settings, disc type, frequency of use, temperature, and mix of CDs vs. DVDs burned.

## Environmental conditions

Item		Description	
Temperature/ humidity	During operation	10°C~35°C	Within 1 month at 40°C Within 120 hours at 60°C
	During storage	-20°C~40°C	
	During transportation	-20°C~60°C	
	During operation	20%~80%RH	No condensation
	During storage	5%~85%RH	No condensation
	During transportation	5%~85%RH	No condensation
	Guaranteed operating range	<p>Based on the following conditions</p> <p>Humidity (%)</p> <p>Temperature (°C)</p>	

## Interfaces

Item	Description	
Ethernet	1	<ul style="list-style-type: none"> <li>• 100Base-TX</li> <li>• 1000Base-T</li> </ul>
Authentication keypad	2	USB 2.0

## ***Ink and Disc***

### ***Ink cartridges***

You can use the following ink cartridges with this product:

<b>Ink cartridge</b>	<b>Part numbers</b>
Cyan	C13S020447
Light Cyan	C13S020448
Light Magenta	C13S020449
Magenta	C13S020450
Yellow	C13S020451
Black	C13S020452

To purchase a PP-100N Series exclusive ink cartridge, check with the dealer where you purchased your PP-100N or access either of the following urls:

<http://www.discproducer.epson-europe.com> (Europe)

<http://www.discproducer.epson.com> (United States and Canada)

### ***Discs***

Epson offers the specified CD-R and DVD-R discs for all your printing needs.